



# ***COOLING TOWER DRIVES***

Cooling Tower Drive Features. . . . .E-2  
Selection of Units, Classes of Service,  
Service Factors . . . . .E-3  
Outline Dimensions  
    Models 5000, 8000, 9000 . . . . .E-4





## COOLING TOWER DRIVES

### BASIC SPECIFICATIONS

- Power ratings from 12 HP to 168 HP.
- Output torque capability to 31,000 inch/lbs.
- Ratios from 2.62:1 to 7.33:1.

### STANDARD FEATURES

- Heavy duty alloy cast iron housings provide vibration dampening, reduced noise level, precision gear and bearing alignment under load
- Heavy duty matched and lapped nickel alloy spiral bevel gears for efficient operation and durability
- High capacity tapered roller bearings at all bearing positions
- Superior strength high alloy steel fan shafts
- Double lip, spring loaded, extended wear life input seals
- Five channel labyrinth type fan shaft seal to exclude and expel foreign material
- Gear sets and fan shafts phosphate coated to prevent gear profile scoring during start-up and run in, and shaft fan/coupling interface fretting corrosion
- Hub City "counter flow" bearing and gear lubrication system to optimize unit life
- High volume isolated sloped bottom condensation sump to enhance lubrication and bearing life in the most hostile environments
- Internal and external housing surfaces double prime coated to maximize corrosion resistance
- External housing surfaces finish coated with satin gloss industrial enamel for additional corrosion protection

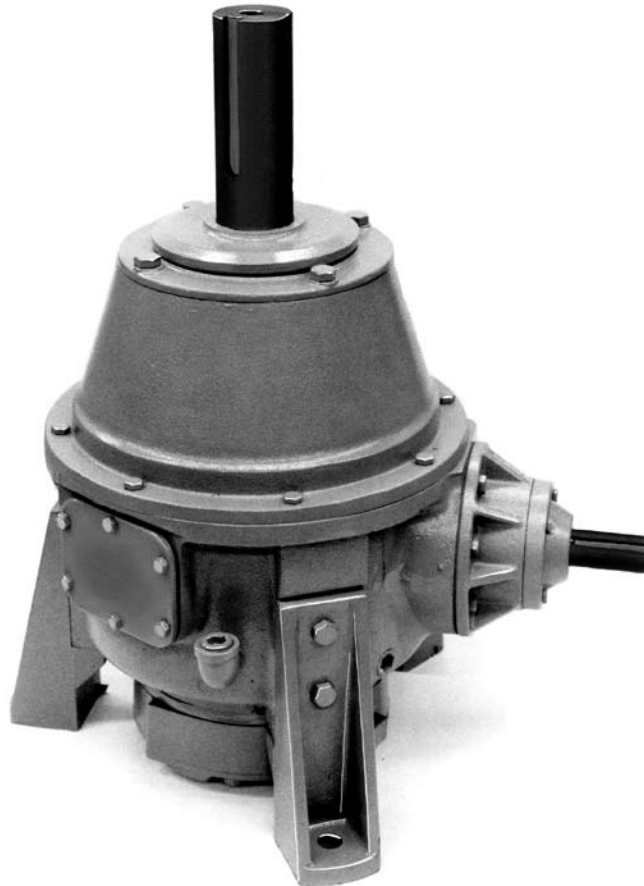

### STANDARD FEATURES (con't)

- All internal components and surfaces factory coated with a corrosion resistant material to facilitate site storage prior to installation
- Large inspection ports
- Oil fill, level and drain ports for remote service plumbing
- Units are designed using AGMA (American Gear Manufacturers Association) and CMI (Cooling Technology Institute) as guidelines

### OPTIONAL FEATURES

- Extreme low temperature operation (see page E3)
- Fan shaft contact lip seals and heavy-duty industrial breathers
- Oil level column sight gages for remote observation
- Hub City cooling tower drives can be economically factory modified to meet unique application and/or industrial/civil code requirements.



**RATINGS & SELECTION**  
**RATINGS FOR CLASS 1 SERVICE (1.0 SERVICE FACTOR)**

1750 RPM INPUT	MODEL NO.	5000			8000					9000				
	GEAR RATIO	2.62	3.27	3.78	3.25	3.78	4.11	4.86	5.57	6.67	4.56	5.50	6.50	7.33
	HORSEPOWER	23.4	17.7	12.5	98.0	95.0	82.0	56.0	50.0	32.0	168.0	156.0	104.0	86.0

1450 RPM INPUT	MODEL NO.	5000			8000					9000				
	GEAR RATIO	2.62	3.27	3.78	3.25	3.78	4.11	4.86	5.57	6.67	4.56	5.50	6.50	7.33
	HORSEPOWER	20.0	14.0	10.7	82.0	79.0	66.0	46.6	43.0	27.7	144.0	126.0	89.0	69.0

1150 RPM INPUT	MODEL NO.	5000			8000					9000				
	GEAR RATIO	2.62	3.27	3.78	3.25	3.78	4.11	4.86	5.57	6.67	4.56	5.50	6.50	7.33
	HORSEPOWER	16.4	11.0	8.6	65.0	62.5	54.0	37.3	33.0	22.3	115.0	100.0	67.0	55.0

**TABLE II – SERVICE FACTORS\***

Light Air Conditioning, Intermittent Duty cycle, Seasonal Application . . . . .	1.50
Continuous Industrial Service, 24 Hours Per Day, Large Air Conditioning . . . . .	1.75
Heavy-duty Industrial, Continuous 24 Hours Per Day, High Loading . . . . .	2.00
†Multi-Cylinder engines, Heavy-duty Service . . . . .	3.00

\*THE COOLING TOWER INSTITUTE (CTI) RECOMMENDS A SERVICE FACTOR OF 2.00 FOR ALL APPLICATIONS.

†CONSULT WITH FACTORY ENGINEERING ON APPLICATION.

**ENGINEERING FORMULAS**

$$\text{Gear Ratio} \times \frac{\text{Motor RPM}}{\text{Fan RPM}}$$

$$\text{Fan tip Speed (ft./Min)} = \text{fan Diameter (ft.)} \times \text{Fan speed (RPM)} \times 3.1416$$

$$\text{Fan RPM} \times \frac{\text{Motor RPM}}{\text{Gear Ratio}}$$

EXAMPLE: A 24 H.P. Motor is required on a Wet Tower with a fan speed of 320 RPM. The motor speed will be 1750 RPM. This will be for year-around heavy industrial use.

The approximate Gear Ratio can be determined by dividing Motor RPM by Fan RPM (i.e. 1750 ÷ 320 = 5.47). the Service Factor is selected by referring to Table II (i.e. 2.0). The required Class I Rating is determined by multiplying the Motor H.P. by the Service Factor (i.e. 25.0 x 2.0 = 50.0 H.P.)

A Gear Drive can now be selected by referring to the table for CLASS I HORSEPOWER @ 1750 RPM INPUT. The MODEL 8000, 5.57:1 Ratio, will be the best selection with an Output Fan Speed of 314 RPM. Page E-4 illustrates full dimension and mounting particulars. TO ORDER, SPECIFY MODEL AND GEAR RATIO.

**COLD TEMPERATURE OPERATION**

For cold temperature operation Hub City can factory install thermostatically controlled heaters or supply low temperature synthetic lubricant. Refer to Section R for lubrication instructions or contact the factory.





## OUTLINE DIMENSIONS

### SERIES 5000



RATIO	WR <sup>2</sup> MOMENT OF INERTIA REFERRED TO –	
	HIGH SPEED SHAFT	LOW SPEED SHAFT
2.62:1	4.7 lb-in <sup>2</sup>	31.9 lb-in <sup>2</sup>
3.27:1	3.9 lb-in <sup>2</sup>	41.9 lb-in <sup>2</sup>
3.78:1	3.5 lb-in <sup>2</sup>	49.3 lb-in <sup>2</sup>

DRY SHIPPING WEIGHT . . . . .97 lbs.

HUB CITY LUBRICANT RECOMMENDED  
SEE SECTION R.

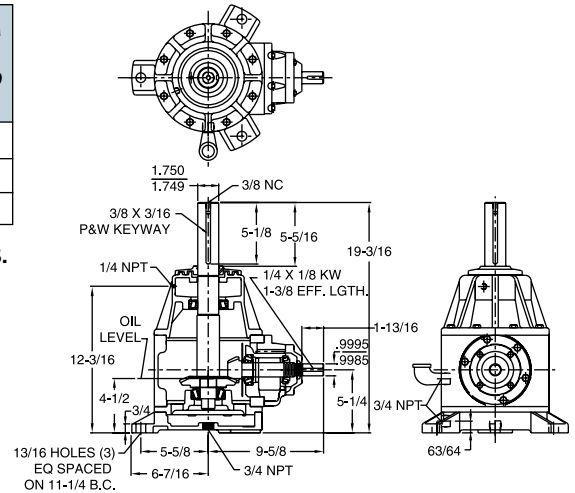

### SERIES 8000



RATIO	WR <sup>2</sup> MOMENT OF INERTIA REFERRED TO –	
	HIGH SPEED SHAFT	LOW SPEED SHAFT
*3.25:1	32.0 lb-in <sup>2</sup>	443.6 lb-in <sup>2</sup>
*3.78:1	35.7 lb-in <sup>2</sup>	510.2 lb-in <sup>2</sup>
4.11:1	33.6 lb-in <sup>2</sup>	568.0 lb-in <sup>2</sup>
4.86:1	28.7 lb-in <sup>2</sup>	678.0 lb-in <sup>2</sup>
5.57:1	25.4 lb-in <sup>2</sup>	768.4 lb-in <sup>2</sup>
6.67:1	21.5 lb-in <sup>2</sup>	957.0 lb-in <sup>2</sup>

\* MFG. TO ORDER – CONSULT FACTORY FOR PRICE AND DELIVERY.

DRY SHIPPING WEIGHT . . . . . 270 lbs.

HUB CITY LUBRICANT RECOMMENDED  
SEE SECTION R.

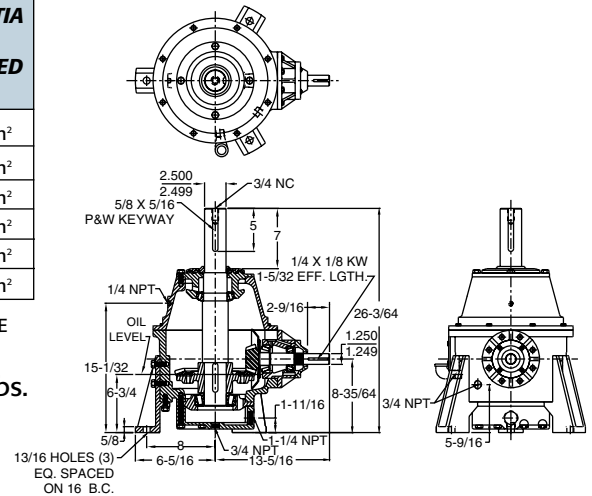

### SERIES 9000



RATIO	WR <sup>2</sup> MOMENT OF INERTIA REFERRED TO –	
	HIGH SPEED SHAFT	LOW SPEED SHAFT
4.56:1	91.4 lb-in <sup>2</sup>	1900.5 lb-in <sup>2</sup>
5.50:1	72.9 lb-in <sup>2</sup>	2206.9 lb-in <sup>2</sup>
6.50:1	60.1 lb-in <sup>2</sup>	2540.0 lb-in <sup>2</sup>
7.33:1	53.8 lb-in <sup>2</sup>	2892.9 lb-in <sup>2</sup>

DRY SHIPPING WEIGHT . . . . . 425 lbs.

HUB CITY LUBRICANT RECOMMENDED  
SEE SECTION R.

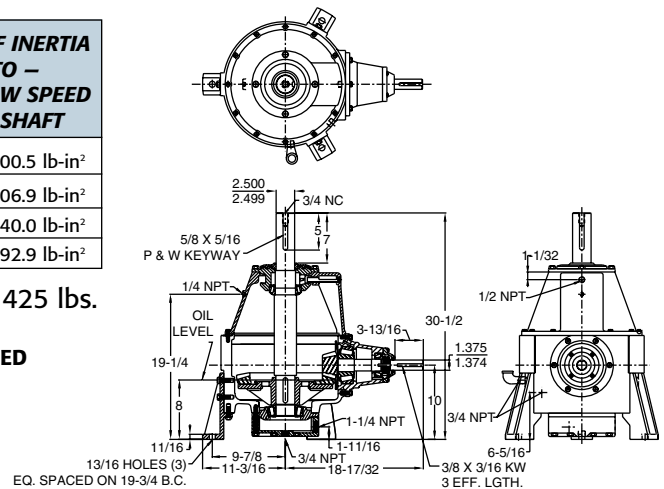

DIMENSIONS SHOWN ARE FOR REFERENCE ONLY.  
CERTIFIED PRINTS ARE AVAILABLE UPON REQUEST.