



ELECTRIC MOTORS

Electric Motors

Introduction.....	H-2
Three Phase TEFC General Purpose Motors.....	H-3
Single Phase TEFC General Purpose Motors.....	H-4
Totally Enclosed Brakemotors.....	H-4
Washdown Duty Motors	H-5 & H-7
Inverter Duty Motors	H-6
Permanent Magnet DC Motors.....	H-7
Motor Dimensions Table	H-8



ELECTRIC MOTORS

Performance matched to Hub City gear drives.



BASIC SPECIFICATIONS

- Power Ratings from 1/4 to 50 hp
- 1.15 Service Factor
- Operating Speed 1750 rpm
- Single Phase or Three Phase Design

STANDARD FEATURES

- Motors Produced by Regal Beloit for High Efficiency, Reliability and Durability
- UL Recognized and CSA Certified
- Ball Bearings for Endurance and Strength
- Totally Enclosed General Purpose Motors Feature Steel Frames
- Brake Motors Feature Stearns Brakes, Bolt-On Removable Bases
- Washdown Motors Feature USDA Approved White Epoxy Paint, 303 Stainless Steel Shafts, Internal Corrosion Resistant Coatings and Class F Insulation System
- Inverter Duty Motors Feature Encoder and Brake Provisions, Class F Insulation System, and Three Year Warranty
- DC Motors Feature Oversized Brushes for Long Life, Class F Insulation System, and Two Year Warranty.

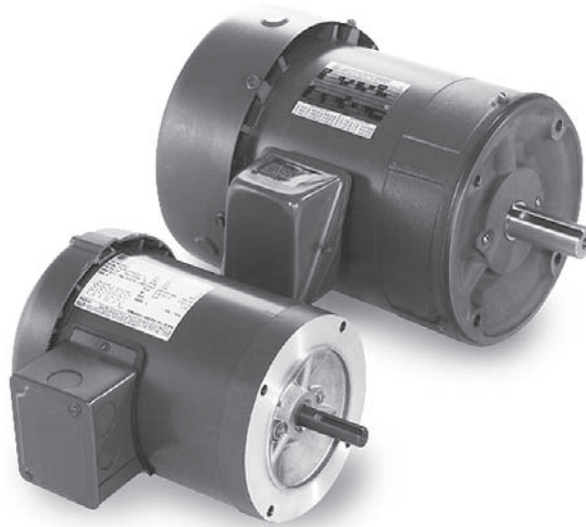

OPTIONAL FEATURES

- Adjustable Speed Motor Controls Available
- Modified Standard and Custom Designs
- CleanLine™ Washdown and BISSC® Configurations
- Unique or Harsh Environment Adaptations
- Motor/Gear Drive Package Incentives Available, Consult Factory

*Don't see the motor you need?
Contact Hub City.
Many more stock motors available.*



THREE PHASE TEFC GENERAL PURPOSE



FEATURES:

- Ball bearings, mechanically locked on shaft end
- 1.15 Service factor
- Rolled steel 56-145T frame motors
- UL Recognized and CSA Certified

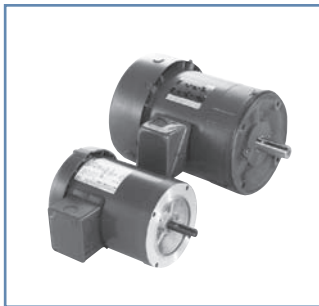

THREE PHASE TEFC 1750 RPM C-FACE MOTORS

HP	VOLTS	FRAME	CAT. NO.	NOM. EFF.	F.L. AMPS	WEIGHT LBS	"LQ" DIM.	FOOTNOTE
1/4	208-230/460	56C	G547	66.0	1.2-1.3/.65	14	7.88	20, 24
1/3	208-230/460	56C	G502	68.0	1.5-1.6/0.8	15	8.13	20, 24
1/2	208-230/460	56C	G507	68.0	2.1-2.2/1.1	17	8.63	20, 24
3/4	208-230/460	56C	G522	75.5	2.7-2.8/1.4	21	9.13	20, 24
1	208-230/460	56C	G527	77.0	3.5-3.6/1.8	27	10.26	20
1-1/2	208-230/460	56C	G541	80.0	4.8-4.8/2.4	29	10.26	20
2	208-230/460	56C	G544	82.5	6.0-5.8/2.9	39	11.75	20
3	208-230/460	182TC	C223	82.5	8.0/4.0	76	13.07	F, 24
5	208-230/460	184TC	C224	86.5	13.0/6.5	92	14.07	F, 20, 24
7-1/2	208-230/460	213TC	C225	87.5	22.0-19.4/9.7	103	16.09	F, 20, 24
10	208-230/460	215TC	C226	88.5	27.6-25.0/12.5	135	17.59	F, 20, 24
15	208-230/460	254TC	C227	88.5	41.0-38.6/19.3	179	19.24	AL, F, 24
20	208-230/460	256TC	(1) U724	91.0	51.0/25.5	225	20.99	AL, F, 20, 24
25	208-230/460	284TC	(1) U725	92.4	68.0-63.0/31.5	425	21.68	F, 20, 24
30	208-230/460	286TC	(1) U726	92.4	81.0-74.0/37.0	455	23.18	F, 20, 24
40	203/460	324TC	(1) U727	92.4	100/50.0	543	23.97	F, 20, 24
50	203/460	326TC	(1) U728	92.4	122/61.0	600	25.47	F, 20, 24

NOTES: (1) FRAME IS C FACE WITH RIGID BASE

FEATURES:

- Ball bearings, mechanically locked on shaft end
- 1.15 Service factor
- Rolled steel 56-145T frame motors
- UL Recognized and CSA Certified



575 VOLT THREE PHASE TEFC 1750 RPM C-FACE MOTORS



HP	VOLTS	FRAME	CAT. NO.	NOM. EFF.	F.L. AMPS	WEIGHT LBS	"LQ" DIM.	FOOTNOTE
1/3	575	56C	(1) G503	68.0	0.64	15	8.13	24
1/2	575	56C	(1) G508	68.0	0.90	18	8.63	24
3/4	575	56C	(1) G523	75.5	1.10	20	9.13	24
1	575	56C	(1) G528	77.0	1.45	26	10.26	
1-1/2	575	56C	(1) G548	80.0	1.90	28	10.26	
2	575	145TC	(1) G549	82.5	2.25	41	11.57	
3	575	182TC	(2) C383	87.5	3.40	77	13.07	F, 24
5	575	184TC	(2) C387	88.5	5.20	87	14.03	F, 24
7-1/2	575	213TC	(2) C391	89.5	8.00	122	16.35	F, 24
10	575	215TC	(2) C394	89.5	10.40	135	17.85	F, 24

NOTES:(1) C FACE - FOOTLESS

(2) C FACE WITH REMOVABLE BASE

FOOTNOTES:

AL ALUMINUM FRAME CONSTRUCTION
F CLASS F INSULATION

20 RATED 60/50 HERTZ, 190/380 OR 380 VOLT AT NEXT LOWER HORSEPOWER
24 MOTOR WILL NOT ACCEPT BRAKE KIT

APPLICATION GUIDELINES

Guidelines for Application General Purpose, Three Phase Motors on Variable Frequency Drives Meets NEMA MG-1-1998 Part 30 and Part 31 Section 4.4.2

ENCLOSURE	EFFICIENCY	FRAME	10:1 VARIABLE TORQUE 2:1 C.T.	MAXIMUM INVERTER TO MOTOR CABLE LENGTH @ 3KHZ CARRIER		
				230 V	460 V	575 V
Totally Enclosed	Standard	56-326	X	600 ft	125 ft	40 ft

Don't see the motor you need?
Contact Hub City.
Many more stock motors available.

- CONTACT MARATHON ELECTRIC FOR GUIDELINES IN APPLYING EXPLOSION PROOF MOTORS ON INVERTERS.
- CARRIER FREQUENCY IS MEASURED PHASE-TO-PHASE, NOT PHASE-TO-BUS. HIGHER CARRIER FREQUENCIES REQUIRE SHORTER CABLE CONTACT HUB CITY FOR DETAILS.

SPECIFICATIONS ARE SUBJECT TO CHANGE WITHOUT NOTICE.

CALL: (605) 225-0360 • FAX: (605) 225-0567

H-3



SINGLE PHASE TEFC GENERAL PURPOSE & TOTALLY ENCLOSED BRAKEMOTORS

SINGLE PHASE TEFC 1750 RPM C-FACE MOTORS

FEATURES:

- Ball bearings, mechanically locked on shaft end
- Heavy gauge steel frame
- Capacitor start design for high starting torque
- 1.15 Service factor
- UL Recognized and CSA Certified

HP	VOLTS	FRAME	CAT. NO.	F.L. AMPS	WEIGHT LBS.	"LQ" DIM.	FOOTNOTES
1/4	115/208-230	56C	G511	4.2/2.1-2.1	16	7.88	N,2,17,24
1/3	115/208-230	56C	G513	6.0/3.0-3.0	18	8.38	2, 24
1/2	115/208-230	56C	G515	8.0/4.0-4.0	23	9.13	2, 24
3/4	115/208-230	56C	G517	11.0/5.4-5.5	30	10.26	2
1	115/208-230	56C	G519	13.4/6.8-6.7	31	10.76	2
1-1/2	115/208-230	56C	G531	15.2/8.2-7.6	40	11.76	1



FOOTNOTES:

- | | | | |
|---|---|----|--------------------------------------|
| N | TOTALLY ENCLOSED, NON-VENTILATED | 2 | CAPACITOR START INDUCTION RUN DESIGN |
| 1 | CAPACITOR START/CAPACITOR RUN DESIGN FOR REDUCED AMPERAGE | 17 | 1.0 SERVICE FACTOR |
| | | 24 | MOTOR WILL NOT ACCEPT A BRAKE KIT |

SINGLE PHASE TEFC 1750 RPM C-FACE BRAKEMOTORS

FEATURES:

- Fail-safe, spring set Stearns brake for holding or stopping
- Brake has manual wear adjustment up to 10lb.-ft. for longer pad life
- Manual release lever on rear of brake housing
- Brake leads are terminated at the brake
- Vertical or horizontal mounting
- Brake coil voltage matches motor voltages
- Bolt-on, easily removable rigid base
- Ball bearings, mechanically locked on shaft end
- 1.15 Service factor
- Nameplated 60/50 hertz at next lowest horsepower
- UL Recognized and CSA Certified

HP	VOLTS	FRAME	CAT. NO.	BRAKE RATING	F.L. AMPS	WEIGHT LBS.	"LQ" DIM.	FOOTNOTES
1/3	115/208-230	56C	D400	3	6.6/3.1-3.3	33	14.14	2
1/2	115/208-230	56C	D401	3	8.8/4.2-4.4	35	14.14	2
3/4	115/208-230	56C	D402	6	11.0/5.4-5.5	38	14.64	2
1	115/208-230	56C	D403	6	13.4/6.8-6.7	40	15.14	2
1-1/2	115/208-230	56C	D404	10	15.2/8.2-7.6	53	16.14	1



FOOTNOTES:

- | | |
|---|---|
| 1 | CAPACITOR START/CAPACITOR RUN DESIGN FOR REDUCED AMPERAGE |
| 2 | CAPACITOR START INDUCTION RUN DESIGN |

THREE PHASE TEFC 1750 RPM C-FACE BRAKEMOTORS

FEATURES:

- In addition to the Single Phase Features above:
- Brake leads routed through motor conduit box (TENV only)
- Suitable for vertical mounting, 10 lb.-ft. and smaller
- CR²⁰⁰ Corona resistant magnet wire (motor can be operated 10:1 variable torque and 2:1 constant torque)
- 1.15 Service factor, 1.0 Service factor where footnoted
- Bolt-on, easily removable rigid base



HP	VOLTS	FRAME	CAT. NO.	BRAKE RATING	F.L. AMPS	WEIGHT LBS.	"LQ" DIM.
1/3	208-230/460	56C	D450	3	1.8-1.6/0.8	31	13.67
1/2	208-230/460	56C	D452	3	2.3-2.4/1.2	32	14.17
3/4	208-230/460	56C	D454	6	2.9-3.0/1.5	33	14.17
1	208-230/460	56C	D456	6	3.5-3.6/1.8	35	15.17
1-1/2	208-230/460	56C	D457	10	4.8-4.8/2.4	41	15.20
2	208-230/460	145TC	C403	10	6.0-5.8/2.9	48	16.65



Don't see the motor you need?
Contact Hub City.
Many more stock motors available.



WASHDOWN DUTY

**SINGLE PHASE
TOTALLY
ENCLOSED
1750 RPM
C-FACE
WASHDOWN
DUTY MOTORS**

FEATURES:

- Double sealed ball bearings
- 303 Stainless steel shaft with spring loaded contact seals in each endshield
- Electronic encapsulated starting switch is impervious to moisture
- Cast conduit box with threaded openings, stainless steel cover
- Internal corrosion resistant coatings on frame, base, endshields, rotor and stator
- USDA-approved, white epoxy paint
- Plugged drain holes in each endshield for all angle mounting
- Capacitor start design for high starting torque
- Class F insulation
- 1.15 Service factor
- Capacity start/induction run design



HP	VOLTS	FRAME	CAT. NO.	F.L. AMPS	WEIGHT LBS.	"LQ" DIM.
1/3	115/208-230	56C	N531	6.4/3.2-3.2	27	8.63
1/2	115/208-230	56C	N523	8.8/4.4-4.4	29	9.13
3/4	115/208-230	56C	N525	10.8/5.4-5.4	31	9.63
1	115/208-230	56C	N527	12.8/6.4-6.4	37	10.13
1-1/2	115/208-230	56C	N529	19.0/9.5-9.5	43	11.63

**THREE PHASE
TOTALLY
ENCLOSED
1750 RPM
C-FACE
WASHDOWN
DUTY MOTORS**

FEATURES:

- Variable torque (6-60Hz) 1.0 Service Factor on VFD
- See Inverter Duty column for constant torque capability
- Double sealed ball bearings
- 303 Stainless steel shaft with spring loaded contact seals in each endshield
- Cast conduit box with threaded openings, stainless steel cover
- Internal corrosion resistant coatings on frame, base, endshields, rotor and stator
- USDA-approved, white epoxy paint
- Plugged drain holes in each endshield for all angle mounting
- Stainless steel fan guard
- MAX GUARD® Class F insulation system
- 1.15 Service factor
- Rigid mounting base



SUITABLE FOR USE ON VFD, SEE INVERTER DUTY COLUMN BELOW.

HP	VOLTS	FRAME	CAT. NO.	INVERTER DUTY	NOM. EFF.	F.L. AMPS	WEIGHT LBS.	"LQ" DIM.	FOOTNOTES
1/4	208-230/460	56C	N564	6:1 CT	67.0	1.1-1.1/6	21	8.63	N
1/3	208-230/460	56C	N565	6:1 CT	68.0	1.7-1.7/9	23	8.63	N
1/2	208-230/460	56C	N567	6:1 CT	78.5	1.8-1.8/9	27	8.00	N
3/4	208-230/460	56C	N599	6:1 CT	80.0	2.5-2.5/1.3	30	8.50	N
1	208-230/460	56C	N602	6:1 CT	80.0	3.6-3.6/1.8	31	9.50	N
1-1/2	208-230/460	56C	N606	6:1 CT	80.0	5.0-5.0/2.5	36	11.00	N
2	208-230/460	56C	N611	3:1 CT	81.5	6.2-6.2/3.1	38	10.63	

FOOTNOTES:

N TOTALLY ENCLOSED, NON-VENTILATED

*Don't see the motor you need?
Contact Hub City.
Many more stock motors available.*



THREE PHASE INVERTER DUTY

**THREE PHASE
TOTALLY
ENCLOSED
NON-VENTILATED
1750 RPM
C-FACE INVERTER
DUTY MOTORS**

FEATURES:

- MAX GUARD® Class F insulation system
- Constant torque operation from 0 to base speed on Vector Drive
- Constant horsepower to twice base RPM
- Continuous duty at 40° C ambient
- Optimized for operation with IGBT inverter (NEMA Design A)
- Normally closed thermostats (one per phase)
- Removable Base on some models, as noted
- Ball bearing
- Field reversible to F2 (except where noted)
- Encoder and brake provisions included on opposite drive end (maximum 10 lb-ft brake)
- UL Recognized and CSA Certified (contact factory for CE marking)
- Three year warranty
- Rigid mounting base

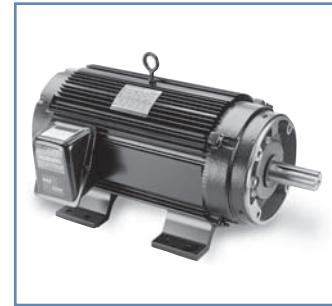

HP	VOLTS	RANGE	FRAME	CAT. NO.	F.L. AMPS	WEIGHT LBS.	"LQ" DIM.	FOOTNOTES
1/4	230/460	1000:1	56C	Y592	1.2	17	9.70	S, 13
1/2	230/460	1000:1	56C	Y534	1.6/0.8	28	11.42	S, 6, 13
1	230/460	1000:1	143TC	Y536	3.0/1.5	43	12.92	S, 6, 13
2	230/460	1000:1	145TC	Y551	6.0/3.0	70	12.56	
3	230/460	1000:1	182TC	Y541	8.4/4.2	96	15.32	AL
5	230/460	1000:1	184TC	Y543	13.0/6.5	98	16.32	AL
7-1/2	230/460	1000:1	213TC	Y545	21.4/10.7	146	17.12	AL
10	230/460	1000:1	215TC	Y547	27.0/13.5	159	19.62	AL

FOOTNOTES:

AL ALUMINUM FRAME CONSTRUCTION
S STEEL FRAME CONSTRUCTION

6 BOLT-ON, REMOVABLE BASE FOR FOOTLESS MOUNTING OPTION
13 F1 MOUNTING ONLY, CANNOT REASSEMBLE TO F2

**THREE PHASE
575 VOLT
TOTALLY
ENCLOSED
NON-VENTILATED
1750 RPM
C-FACE INVERTER
DUTY MOTORS**

FEATURES:

- MAX GUARD® Class F insulation system
- Constant torque operation from 0 to base speed on Vector Drive
- Constant horsepower to twice base RPM
- Continuous duty at 40° C ambient
- Optimized for operation with IGBT inverter (NEMA Design A)
- Normally closed thermostats (one per phase)
- Removable base on some models, as noted
- Ball bearing
- Field reversible to F2 (except where noted)
- Encoder and brake provisions included on opposite drive end (maximum 10 lb-ft brake)
- UL Recognized and CSA Certified (contact factory for CE marking)
- Three year warranty
- Rigid mounting base

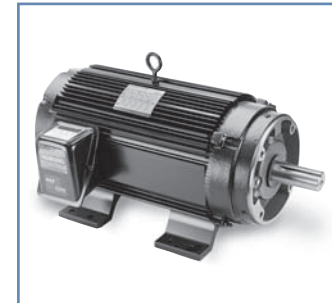

*Don't see the motor you need?
Contact Hub City.
Many more stock motors available.*

HP	VOLTS	RANGE	FRAME	CAT. NO.	F.L. AMPS	WEIGHT LBS.	"LQ" DIM.	FOOTNOTES
1/2	575	1000:1	56C	Y555	0.6	28	11.42	S, 6, 13
1	575	1000:1	56C	Y556	1.2	41	12.92	S, 6, 13
2	575	1000:1	145TC	Y557	2.4	70	12.56	
3	575	1000:1	182TC	Y558	3.4	96	15.32	AL
5	575	1000:1	184TC	Y559	5.4	98	16.32	AL
7-1/2	575	1000:1	213TC	Y560	7.0	146	17.12	AL
10	575	1000:1	215TC	Y561	10.8	159	19.62	AL

FOOTNOTES:

AL ALUMINUM FRAME CONSTRUCTION
S STEEL FRAME CONSTRUCTION

6 BOLT-ON, REMOVABLE BASE FOR FOOTLESS MOUNTING OPTION
13 F1 MOUNTING ONLY, CANNOT REASSEMBLE TO F2



PERMANENT MAGNET DC MOTORS

SCR RATED,
TOTALLY ENCLOSED,
1750 RPM
C-FACE WITH
REMOVABLE BASE

FEATURES:

- Class F insulation
- NEMA C-Face with removable rigid base
- Oversized brushes for extra long life
- Permanently lubricated sealed ball bearings
- Linear speed/torque characteristics over entire speed range
- High starting torque, high peak current capability
- Usable on PWM type DC adjustable speed drives at higher HP rating
- Easy brush access with unique brush holder design
- UL Recognized and CSA Certified
- 2 year warranty



HP	DC VOLTS	FRAME	ENCL.	CAT. NO.	C.T. SPEED. RANGE	F.L. AMPS	*PWM HP RATING	WEIGHT LBS.	"LQ" DIM.	FOOTNOTES
1/4	90	56C	TEFC	Z602	2:1	2.5	0.40	19	8.75	
1/4	180	56C	TEFC	Z603	2:1	1.4	0.50	22	9.25	
1/3	90	56C	TEFC	Z604	2:1	3.5	0.50	23	9.25	
1/3	180	56C	TEFC	Z605	2:1	1.7	0.50	22	9.25	
1/2	90	56C	TEFC	Z606	2:1	5.0	0.70	24	9.75	
1/2	180	56C	TEFC	Z607	2:1	2.5	0.56	25	9.75	
3/4	90	56C	TEFC	Z610	2:1	7.6	1.00	27	11.75	
3/4	180	56C	TEFC	Z611	2:1	3.8	1.00	27	11.75	
1	90	56C	TEFC	Z612	2:1	10.0	1.25	40	13.75	
1	180	56C	TEFC	Z613	2:1	5.0	1.25	40	12.75	
1-1/2	180	56C	TEFC	Z614	2:1	7.6	1.75	51	14.75	
2	180	145TC	TEFC	Z616	2:1	9.5	2.00	78	18.03	84

FOOTNOTES: 84 NEMA 145TC FACE MOUNTING WITH REMOVABLE 182T RIGID BASE

85 NOT TACH ADAPTABLE

WASHDOWN,
SCR RATED,
TOTALLY ENCLOSED,
1750 RPM
C-FACE WITH
REMOVABLE BASE

FEATURES:

- Class F insulation
- NEMA C-Face with removable rigid base
- Oversized brushes for extra long life
- Doubled sealed, oversized ball bearings
- Corrosion resistant 303 stainless steel shaft
- High temperature, moisture resistant lubricant
- Exterior and interior components protected with enamel & polyester compounds
- Aluminum conduit box, threaded and gasketed
- "V" ring Forsheda seals
- Drains at 3:00, 6:00, 9:00 and 12:00 locations
- Sealed machine fits
- Stainless steel nameplate
- USDA approved white epoxy paint
- UL Recognized and CSA Certified
- 2 year warranty

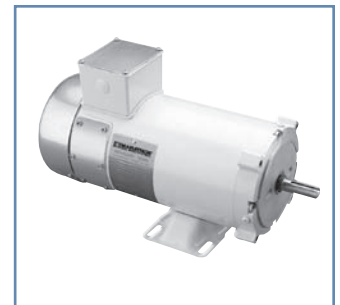

HP	DC VOLTS	FRAME	ENCL.	CAT. NO.	C.T. SPEED. RANGE	F.L. AMPS	*PWM HP RATING	WEIGHT LBS.	"LQ" DIM.
1/4	90	56C	TENV	Z630	20:1	2.7	0.30	23	8.63
1/3	90	56C	TENV	Z631	20:1	3.5	0.56	26	9.63
1/2	90	56C	TENV	Z634	20:1	4.9	0.75	38	11.63
1/2	180	56C	TENV	Z635	20:1	2.4	0.70	39	11.63
3/4	90	56C	TENV	Z636	20:1	7.0	1.25	50	13.63
3/4	180	56C	TENV	Z637	20:1	3.5	1.25	50	13.63
1	90	56C	TEFC	Z638	2:1	10.0	1.25	42	13.75
1	180	56C	TEFC	Z639	2:1	5.0	1.25	42	12.75
1-1/2	180	56C	TEFC	Z641	2:1	7.6	1.75	50	14.75

***SCR PMDC MOTORS ON PWM POWER SUPPLIES**

PULSE WIDTH MODULATED DC CONTROLS HAVE A VOLTAGE OUTPUT SIMILAR TO PURE DIRECT CURRENT WHICH HAS A FORM FACTOR OF 1.05. SCR THYRISTOR DRIVES HAVE A FORM FACTOR OF 1.40. MARATHON ELECTRIC'S NON-EXPLOSION PROOF PMDC, SCR-RATED MOTORS CAN ALSO BE USED WITH PWM CONTROLS, AND DUE TO THE LOWER FORM FACTOR AND THE RESULTANT LOWER HEATING IN THE MOTOR, THEIR RATING CAN BE INCREASED AS INDICATED ABOVE. OPERATION ON PWM CONTROLS WILL ALSO RESULT IN QUIETER OPERATION AND LONGER BRUSH LIFE.



ELECTRIC MOTORS

TYPICAL C-FACE MOTOR

TYPICAL RIGID BASE MOTOR

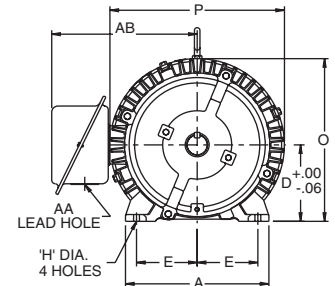
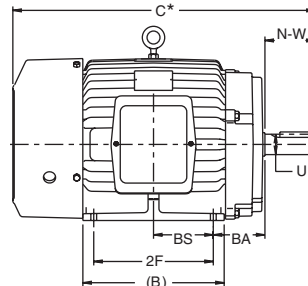
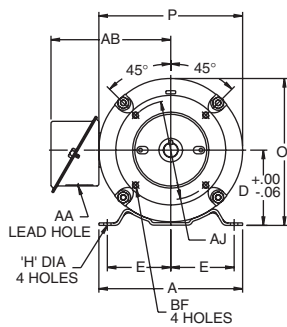
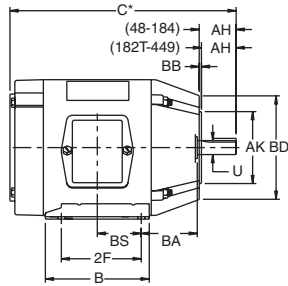

FRAME	D	E	2F	H	O (MAX)	P (MAX)	U	N-W	AA	AB (MAX)	AH	AJ	AK	BA	BB (MIN)	BD (MAX)	BF
48	3.00	2.12	2.75	.34 SLOT	5.83	5.66	.5000	1.50	1/2	-	1.69	3.750	3.000	2.50	.16	5.62	1/4-20
56	3.50	2.44	3.00	.34 SLOT	6.32	5.66	.6250	1.88	1/2	-	2.06	5.875	4.500	2.75	.16	6.50	3/8-16
56H	3.50	2.44	5.00	.34 SLOT	6.74	6.48	.6250	1.88	1/2	-	2.06	5.875	4.500	2.75	.16	6.50	3/8-16
143T	3.50	2.75	4.00	.34	7.45	7.75	.8750	2.25	3/4	7.04	2.12	5.875	4.500	2.25	.16	6.50	3/8-16
145T	3.50	2.75	5.00	.34	7.45	7.75	.8750	2.25	3/4	7.04	2.12	5.875	4.500	2.25	.16	6.50	3/8-16
182	4.50	3.75	4.50	.41	9.38	9.76	.8750	2.25	3/4	8.08	2.12	5.875	4.500	2.75	.16	6.50	3/8-16
184	4.50	3.75	5.50	.41	9.38	9.76	.8750	2.25	3/4	8.08	2.12	5.875	4.500	2.75	.16	6.50	3/8-16
182T	4.50	3.75	4.50	.41	9.38	9.76	1.1250	2.75	3/4	8.08	2.62	7.250	8.500	2.75	.25	9.00	1/2-13
184T	4.50	3.75	5.50	.41	9.38	9.76	1.1250	2.75	3/4	8.08	2.62	7.250	8.500	2.75	.25	9.00	1/2-13
213	5.25	4.25	5.50	.41	11.00	11.50	1.1250	3.00	1	9.31	2.75	7.250	8.500	3.50	.25	9.00	1/2-13
215	5.25	4.25	7.00	.41	11.00	11.50	1.1250	3.00	1	9.31	2.75	7.250	8.500	3.50	.25	9.00	1/2-13
213T	5.25	4.25	5.50	.41	11.00	11.50	1.3750	3.38	1	9.31	3.12	7.250	8.500	3.50	.25	9.00	1/2-13
215T	5.25	4.25	7.00	.41	11.00	11.50	1.3750	3.38	1	9.31	3.12	7.250	8.500	3.50	.25	9.00	1/2-13
254U	6.25	5.00	8.25	.53	14.09	14.27	1.3750	3.75	1-1/4	10.96	3.50	7.250	8.500	4.25	.25	10.00	1/2-13
256U	6.25	5.00	10.00	.53	14.09	14.27	1.3750	3.75	1-1/4	10.96	3.50	7.250	8.500	4.25	.25	10.00	1/2-13
254T	6.25	5.00	8.25	.53	14.09	14.27	1.625	4.00	1-1/4	10.96	3.75	7.250	8.500	4.25	.25	10.00	1/2-13
256T	6.25	5.00	10.00	.53	14.09	14.27	1.625	4.00	1-1/4	10.96	3.75	7.250	8.500	4.25	.25	10.00	1/2-13
284U	7.00	5.50	9.50	.53	14.94	15.88	1.625	4.88	1-1/2	13.19	4.62	9.000	10.500	4.75	.25	11.25	1/2-13
286U	7.00	5.50	11.00	.53	14.94	15.88	1.625	4.88	1-1/2	13.19	4.62	9.000	10.500	4.75	.25	11.25	1/2-13
284T	7.00	5.50	9.50	.53	14.94	15.88	1.875	4.62	1-1/2	13.19	4.38	9.000	10.500	4.75	.25	11.25	1/2-13
286T	7.00	5.50	11.00	.53	14.94	15.88	1.875	4.62	1-1/2	13.19	4.38	9.000	10.500	4.75	.25	11.25	1/2-13
284TS	7.00	5.50	9.50	.53	14.94	15.88	1.625	3.25	1-1/2	13.19	3.00	9.000	10.500	4.75	.25	11.25	1/2-13
286TS	7.00	5.50	11.00	.53	14.94	15.88	1.625	3.25	1-1/2	13.19	3.00	9.000	10.500	4.75	.25	11.25	1/2-13
324U	8.00	6.25	10.50	.66	15.93	15.88	1.875	5.62	2	13.69	5.38	11.000	12.500	5.25	.25	14.00	5/8-11
326U	8.00	6.25	12.00	.66	15.93	15.88	1.875	5.62	2	13.69	5.38	11.000	12.500	5.25	.25	14.00	5/8-11
324T	8.00	6.25	10.50	.66	15.93	15.88	2.125	5.25	2	13.69	5.00	11.000	12.500	5.25	.25	14.00	5/8-11
326T	8.00	6.25	12.00	.66	15.93	15.88	2.125	5.25	2	13.69	5.00	11.000	12.500	5.25	.25	14.00	5/8-11
324TS	8.00	6.25	10.50	.66	15.93	15.88	1.875	3.75	2	13.69	3.50	11.000	12.500	5.25	.25	14.00	5/8-11
326TS	8.00	6.25	12.00	.66	15.93	15.88	1.875	3.75	2	13.69	3.50	11.000	12.500	5.25	.25	14.00	5/8-11
364U	9.00	7.00	11.25	.66	19.00	20.00	2.125	6.38	2-1/2	17.88	6.12	11.000	12.500	5.88	.25	14.00	5/8-11
365U	9.00	7.00	12.25	.66	19.00	20.00	2.125	6.38	2-1/2	17.88	6.12	11.000	12.500	5.88	.25	14.00	5/8-11
364T	9.00	7.00	11.25	.66	19.00	20.00	2.375	5.88	2-1/2	17.88	5.62	11.000	12.500	5.88	.25	14.00	5/8-11
365T	9.00	7.00	12.25	.66	19.00	20.00	2.375	5.88	2-1/2	17.88	5.62	11.000	12.500	5.88	.25	14.00	5/8-11
364TS	9.00	7.00	11.25	.66	19.00	20.00	1.875	3.75	2-1/2	17.88	3.50	11.000	12.500	5.88	.25	14.00	5/8-11
365TS	9.00	7.00	12.25	.66	19.00	20.00	1.875	3.75	2-1/2	17.88	3.50	11.000	12.500	5.88	.25	14.00	5/8-11

*C DIMENSIONS CAN BE CALCULATED BY ADDING THE LQ DIMENSIONS ON MOTOR PAGES H-3 TO H-7 TO THE AH DIMENSION. (C = LQ + AH)



FOR SAFETY AND TO COMPLY WITH LOCAL AND NATIONAL SAFETY CODES, THE PURCHASER OR USER MUST PROVIDE PROTECTIVE GUARDS OVER ALL SHAFT EXTENSIONS AND DEVICES MOUNTED THEREON.

Don't see the motor you need?
Contact Hub City.
 Many more stock motors available.