



PowerTorque® SHAFT MOUNT REDUCERS

- PowerTorque® Features and Description..... G-2
- Nomenclature G-4
- Selection Instructions G-5
- Selection By Horsepower..... G-7
- Mechanical Ratings G-12
- Dimensions..... G-14
- Accessories G-15
- Screw Conveyor Accessories..... G-22

**For Additional
Models of
Shaft Mount
Reducers See
Sections F & J**





PowerTorque® SHAFT MOUNT REDUCERS

Ten models available from 1/4 HP through 200 HP capacity

MANUFACTURING QUALITY

Manufactured to the highest quality standards in the industry, assembled using precision manufactured components made from top quality materials

Designed for the toughest applications in the industry

HOUSINGS

High strength ductile iron housings, rather than cast iron material

GEARING

High Efficiency gearing is manufactured from 8620 steel, case carburized, hardened to RC62, and precision ground, AGMA Class 11, rather than crowned and shaved

OUTPUT BORES

Standard bores range from 1-7/16" through 5-7/16"

RATIOS

Ratios from 9:1, 15:1 and 25:1

SHAFTS

Input shafts are machined from high strength alloy steel and hardened for premium load carrying capability

BEARINGS

Tapered roller bearings are selected for optimum life and load carrying capability

SEALS

Double lip seals feature metal reinforcement and ride on precision ground shaft surfaces for longevity

**98.5%
Efficiency
per Gear Stage!**

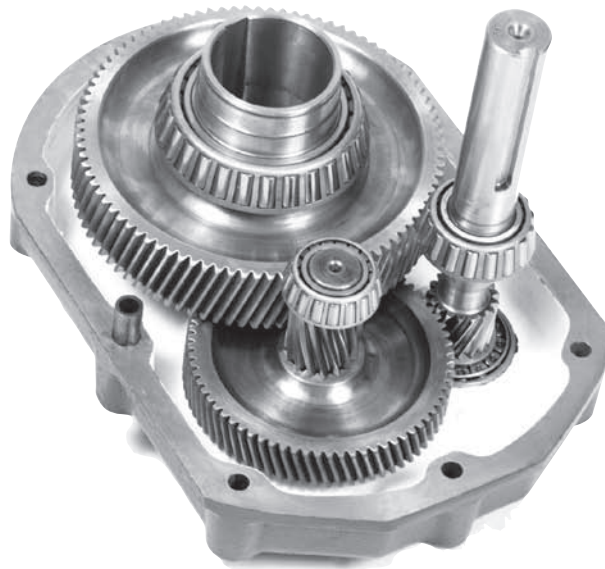

LUBRICATION

Ample lubrication is provided by abundant splash from the large oil sump

INTERCHANGEABILITY

Dimensionally and mechanically interchangeable with most major brands

WARRANTY

Backed by an 18 month warranty for assured dependable longevity while providing trouble free service



THE HUB CITY ADVANTAGE

Hub City PowerTorque® Accessories complete the drive package by providing tapered bushings, backstops, and motor mounts. Screw conveyor drive accessories include adapter flanges and drive shafts.



TAPERED BUSHING KITS

Flanged bushing mount
Removal screws allow for easy demounting
Ductile iron material for shock resistance
Clamp fit, no setscrews
Split design eliminates seizing problems



BACKSTOP ASSEMBLIES

Quick installation on input shaft
Internally installed, sealed from contamination
Lubricated by internal gear lubricant
Designed to operate in either direction



MOTOR MOUNTS

All-Steel construction for rigidity
Compact design eliminates need for motor base
Top plate adjusts for easy tensioning of drive belt
Mounting holes provided match NEMA standards



SCREW CONVEYOR ADAPTER FLANGES

Conform to CEMA standards
Bolt-on design allows easy mounting
Open center for contaminate dropout



SCREW CONVEYOR DRIVE SHAFTS

Machined from high strength alloy steel
Conform to CEMA dimensional standards
Easy installation into standard hollow bore



BELT GUARDS

All-Steel construction
Adjustable to fit a wide range of sheaves and motor frames
Designed for easy installation, no drilling required



DESCRIPTION

DESCRIPTIONS FOR ORDERING SHAFT MOUNT REDUCERS

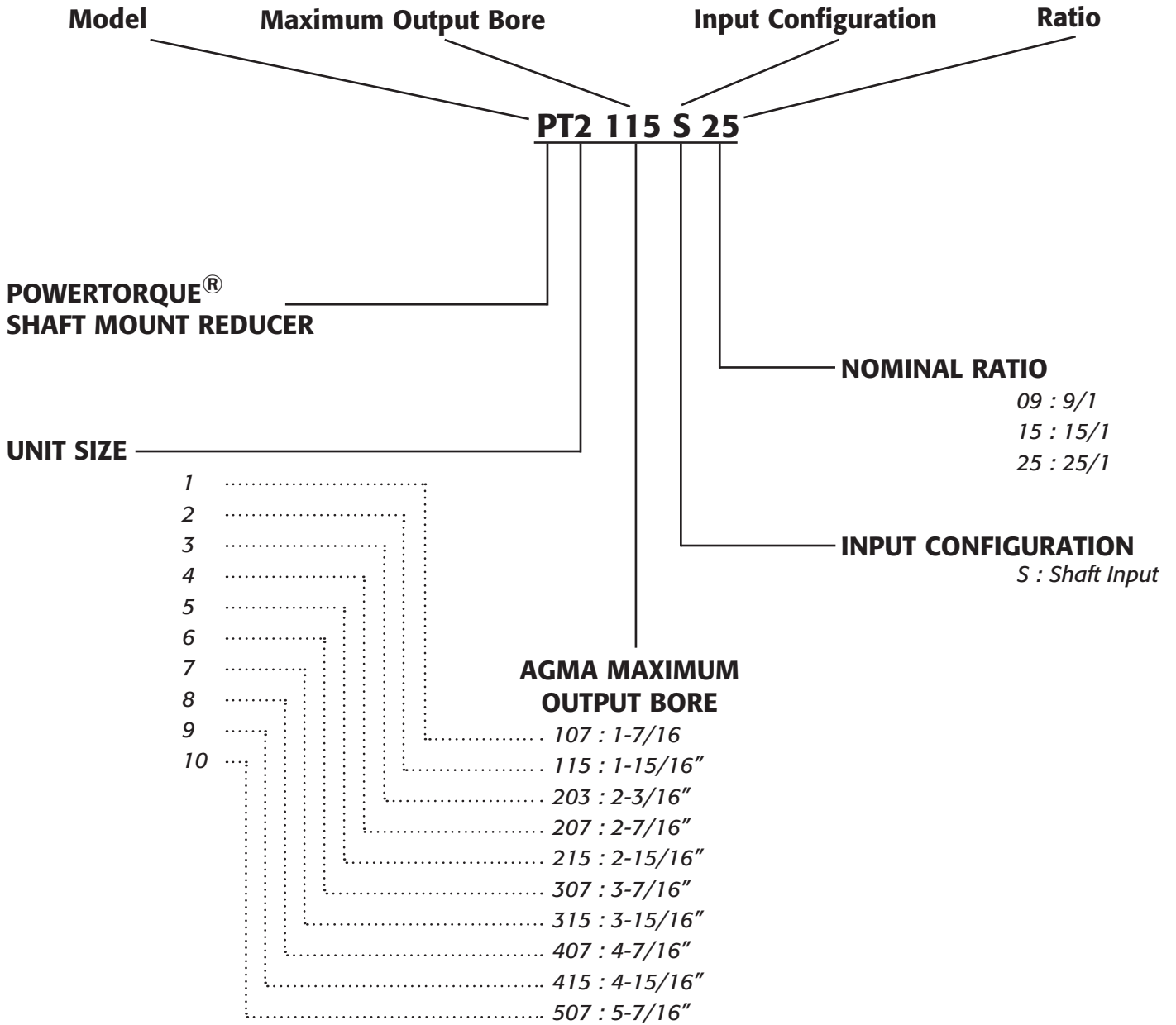

PART NUMBER PREFIXES

- 0270-XXXXX Standard Assembly
- 0271-XXXXX Modified Assembly
- 0273-XXXXX Standard Service Part
- 0275-XXXXX Modified Service Part
- 0279-XXXXX Accessory Kit



SELECTION PROCEDURE

Hub City PowerTorque® reducers are selected on the basis of input horsepower and output speed. There are ten double reduction PowerTorque® Models available in nominal ratios of 9:1, 15:1, and 25:1 with output

speeds to 200 RPM and ratings up to 200 HP. The selection tables have been established so that once the horsepower and driven speed are known the appropriate model can be readily selected.

AGMA LOAD CLASSIFICATION NUMBERS

Determine the AGMA Load Classification Number for your application from the tables in section A. In mechanical drives the presence of shock loads will usually reduce the life of the reducers. In order to provide optimum service in heavily loaded applications, it is necessary to use load classes to adjust the reducer ratings for the stresses created

by different types of loads. The AGMA Load Classes provide for a momentary or starting load of 2.0 times for Class I, 2.8 for Class II, and 4.0 for Class III. Refer to section A for further information and cautions on the selection of proper service factors

LOAD CLASS (S.F.)	UP TO 3 HRS. TOTAL OPERATION PER DAY	3 TO 10 HRS. TOTAL OPERATION PER DAY	OVER 10 HRS. TOTAL OPERATION PER DAY
I (1.0)	Moderate Shock Load	Uniform Load	
II (1.4)	Heavy Shock Load	Moderate Shock Load	Uniform Load
III (2.0)		Heavy Shock Load	Moderate Shock Load

SELECT REDUCER SIZE AND RATIO

Refer to the applicable Selection Table for the AGMA Load Class I, II, or III on pages G-7 to

G-11. Locate the required HP and Output Speed, and read across to find the reducer size.

SELECT TAPERED BUSHINGS

Compare the hollow shaft bore with the diameter of the driven shaft. If the driven shaft is smaller than the maximum bore for the reducer selected, select the proper tapered bushings from the table on page G-15 to adapt

the hollow shaft bore to the diameter of the driven shaft. If the driven shaft diameter is larger than the maximum bore for the reducer selected, it is necessary to either turn down the driven shaft, or select a larger reducer.

SELECT SHEAVE RATIO

To determine the V-belt sheave ratio required to produce the desired output speed, use the following formula: sheave ratio = exact motor RPM / (output RPM X exact gear ratio).

Refer to the catalog of your chosen V-belt supplier to select the most economical V-belt drive to transmit the HP at the required output speed by following the selection procedure outlined in the V-belt catalog.

G



SELECTION PROCEDURE



Refer to the Minimum Diameter for Driven Sheaves listed in the Selection Tables to be certain that your driven sheave selection is larger than the minimum diameter recommended for the reducer selected.

ACCESSORIES:

SELECT MOTOR MOUNT

Select the motor frame and motor mount size from the tables on page G-16 to G-19 based on the reducer size.

SELECT BELT GUARDS

Select belt guards from the tables on pages G-20 and G-21 based on the reducer size.

SELECT SCREW CONVEYOR DRIVE SHAFT AND ADAPTER

Select the CEMA adapter and drive shaft from the tables on page G-22 based on the reducer size.

SELECT BACKSTOP

Optional backstops are available for applications that require the prevention of reverse rotation. Select the backstop from the table on page G-15 based on the reducer size. Backstops are installed on the high speed pinion shaft by removing the cover on the back side (opposite side from the input shaft extension) of the housing.



Backstops are not recommended for applications involving energy absorption and shock or torque loads in excess of reducer ratings or on applications such as chair lifts, amusement rides, etc. where the safety of a person or property is dependent on their function. On such applications, other safety devices should be provided.

Backstops are designed to prevent rotation not more than five times in an 8 hour period with a minimum of one minute in the over-running direction between each engagement. If reversing operation is more frequent or over-running time is less, the application should be referred to the factory.



Lubricants with extreme pressure (EP) additives should not be used in units with backstops installed.

OTHER ACCESSORIES SUPPLIED UPON REQUEST:

Cooling Fans
Mounting Brackets
Auxiliary Seal Kits

NOTE: A torque-arm assembly is supplied with all shaft mount reducers.

For Lubrication and Installation Instructions Refer to Section R.



CLASS I SERVICE

SELECTION BY INPUT HORSEPOWER

HP	OUTPUT RPM	REDUCER SELECTION		MINIMUM SHEAVE DIA.
0.25	4 ~ 70	PT1107-25	PT1107-15	3.0
	71 ~ 85	PT1107-25	PT1107-15	3.0
	86 ~ 115	PT1107-15	PT1107-09	3.0/4.0
	116 ~ 140	PT1107-15	PT1107-09	3.0/4.0
	141 ~ 200	PT1107-09		4.0
0.33	5 ~ 70	PT1107-25	PT1107-15	3.0
	71 ~ 85	PT1107-25	PT1107-15	3.0
	86 ~ 115	PT1107-15	PT1107-09	3.0/4.0
	116 ~ 140	PT1107-15	PT1107-09	3.0/4.0
	141 ~ 200	PT1107-09		4.0
0.50	4 ~ 6	PT2115-25		3.0
	7 ~ 70	PT1107-25	PT1107-15	3.0
	71 ~ 85	PT1107-25	PT1107-15	3.0
	86 ~ 115	PT1107-15	PT1107-09	3.0/4.0
	116 ~ 140	PT1107-15	PT1107-09	3.0/4.0
	141 ~ 200	PT1107-09		4.0
0.75	4 ~ 5	PT3203-25		4.0
	6 ~ 10	PT2115-25		3.0
	11 ~ 70	PT1107-25	PT1107-15	3.0
	71 ~ 85	PT1107-25	PT1107-15	3.0
	86 ~ 115	PT1107-15	PT1107-09	3.0/4.0
	116 ~ 140	PT1107-15	PT1107-09	3.0/4.0
	141 ~ 200	PT1107-09		4.0
1	4 ~ 5	PT4207-25		4.6
	6 ~ 7	PT3203-25		4.0
	8 ~ 15	PT2115-25		3.0
	16 ~ 70	PT1107-25	PT1107-15	3.0
	71 ~ 85	PT1107-25	PT1107-15	3.0
	86 ~ 115	PT1107-15	PT1107-09	3.0/4.0
	116 ~ 140	PT1107-15	PT1107-09	3.0/4.0
	141 ~ 200	PT1107-09		4.0
1.5	4	PT5215-25		5.4
	5 ~ 7	PT4207-25		4.6
	8 ~ 12	PT3203-25		4.0
	13 ~ 23	PT2115-25		3.0
	24 ~ 70	PT1107-25	PT1107-15	3.0
	71 ~ 85	PT1107-25	PT1107-15	3.0
	86 ~ 115	PT1107-15	PT1107-09	3.0/4.0
	116 ~ 140	PT1107-15	PT1107-09	3.0/4.0
2	4 ~ 6	PT5215-25		5.4
	7 ~ 10	PT4207-25		4.6
	11 ~ 17	PT3203-25		4.0
	18 ~ 32	PT2115-25	PT2115-15	3.0
	33 ~ 70	PT1107-25	PT1107-15	3.0
	71 ~ 85	PT1107-25	PT1107-15	3.0
	86 ~ 115	PT1107-15	PT1107-09	3.0/4.0
	116 ~ 140	PT1107-15	PT1107-09	3.0/4.0
	141 ~ 200	PT1107-09		4.0
3	4 ~ 5	PT6307-25		6.2
	6 ~ 10	PT5215-25		5.4
	11 ~ 15	PT4207-25		4.6
	16 ~ 26	PT3203-25		4.0
	27 ~ 51	PT2115-25	PT2115-15	3.0
	52 ~ 70	PT1107-25	PT1107-15	3.0
	71 ~ 85	PT1107-25	PT1107-15	3.0
	86 ~ 115	PT1107-15	PT1107-09	3.0/4.0
	116 ~ 140	PT1107-15	PT1107-09	3.0/4.0
	141 ~ 200	PT1107-09		4.0
5	5 ~ 6	PT7315-25		6.2

HP	OUTPUT RPM	REDUCER SELECTION		MINIMUM SHEAVE DIA.
5 <i>(con't)</i>	7 ~ 9	PT6307-25		6.2
	10 ~ 17	PT5215-25		5.4
	18 ~ 26	PT4207-25	PT4207-15	4.6
	27 ~ 46	PT3203-25	PT3203-15	4.0
	47 ~ 70	PT2115-25	PT2115-15	3.0
	71 ~ 85	PT2115-25	PT2115-15	3.0
	86 ~ 92	PT1107-09	PT2115-15	4.0/3.0
	93 ~ 115	PT1107-15	PT1107-09	3.0/4.0
	116 ~ 140	PT1107-15	PT1107-09	3.0/4.0
	141 ~ 200	PT1107-09		4.0
7.5	4 ~ 6	PT8407-25		6.2
	7 ~ 9	PT7315-25		6.2
	10 ~ 15	PT6307-25		6.2
	16 ~ 26	PT5215-25		5.4
	27 ~ 40	PT4207-25	PT4207-15	4.6
	41 ~ 70	PT3203-25	PT3203-15	4.0
	71 ~ 74	PT3203-25	PT3203-15	4.0
	75 ~ 85	PT2115-25	PT2115-15	3.0
	86 ~ 95	PT2115-15		3.0
	96 ~ 140	PT2115-15		3.0
141 ~ 200		PT2115-09	5.0	
10	4 ~ 6	PT9415-25		8.0
	6 ~ 8	PT8407-25		6.2
	9 ~ 12	PT7315-25		6.2
	13 ~ 20	PT6307-25		6.2
	21 ~ 36	PT5215-25	PT5215-15	5.4
	37 ~ 56	PT4207-25	PT4207-15	4.6
	57 ~ 70	PT3203-25	PT3203-15	4.0
	71 ~ 85	PT3203-25	PT3203-15	4.0
	86 ~ 103	PT3203-15	PT3203-09	4.0/5.0
	104 ~ 115	PT2115-15		3.0
	116 ~ 140	PT2115-15		3.0
	141 ~ 158	PT3203-09		5.0
	159 ~ 200	PT3203-09		5.0
	4 ~ 6	PT10507-25		8.5
	7 ~ 8	PT9415-25		8.0
9 ~ 13	PT8407-25		6.2	
14 ~ 19	PT7315-25		6.2	
20 ~ 32	PT6307-25	PT6307-15	6.2	
33 ~ 56	PT5215-25	PT5215-15	5.4	
57 ~ 70	PT4207-25	PT4207-15	4.6	
71 ~ 85	PT4207-25	PT4207-15	4.6	
86 ~ 93	PT4207-15	PT4207-09	4.6/6.5	
94 ~ 115	PT3203-15	PT3203-09*	4.0/5.0	
116 ~ 140	PT3203-15	PT3203-09*	4.0/5.0	
141 ~ 145		PT3203-09*	5.0	
146 ~ 200		PT3203-09*	5.0	
15	7 ~ 8	PT10507-25		8.5
	9 ~ 12	PT9415-25		8.0
	13 ~ 18	PT8407-25		6.2
	19 ~ 26	PT7315-25	PT7315-15	6.2
	27 ~ 45	PT6307-25	PT6307-15	6.2
	46 ~ 70	PT5215-25	PT5215-15	5.4
	71 ~ 78	PT5215-25	PT5215-15	5.4
	79 ~ 85	PT4207-25	PT4207-15	4.6
	86 ~ 115	PT4207-15	PT4207-09*	4.6/6.5
	116 ~ 140	PT4207-15*	PT4207-09*	4.6/6.5
	141 ~ 200		PT3203-09*	5.0
	20	8 ~ 10	PT10507-25	
11 ~ 15		PT9415-25		8.0
11 ~ 15		PT9415-25		8.0

*ADDITIONAL COOLING PROVISIONS MAY BE REQUIRED. CONSULT FACTORY WITH APPLICATION DETAILS.



SELECTION BY INPUT HORSEPOWER

CLASS I SERVICE CONT.

HP	OUTPUT RPM	REDUCER SELECTION	MINIMUM SHEAVE DIA.	
25 <i>(cont.)</i>	16 ~ 23	PT8407-25	6.2	
	24 ~ 33	PT7315-25 PT7315-15	6.2	
	34 ~ 59	PT6307-25 PT6307-15	6.2	
	60 ~ 70	PT5215-25* PT5215-15*	5.4	
	71 ~ 80	PT5215-25* PT5215-15*	5.4	
	81 ~ 101	PT5215-15* PT5215-09*	5.4	
	102 ~ 132	PT4207-15* PT4207-09*	4.6/6.5	
	133 ~ 140	PT4207-15* PT4207-09*	4.6/6.5	
	141 ~ 163	PT4207-09*	6.5	
164 ~ 200	PT4207-09*	6.5		
30	10 ~ 13	PT10507-25	8.5	
	14 ~ 19	PT9415-25	8.0	
	20 ~ 28	PT8407-25 PT8407-15	6.2	
	29 ~ 41	PT7315-25 PT7315-15	6.2	
	42 ~ 70	PT6307-25 PT6307-15	6.2	
	71 ~ 75	PT6307-25 PT6307-15	6.2	
	76 ~ 115	PT5215-15* PT5215-09*	5.4/7.0	
	116 ~ 125	PT5215-15* PT5215-09*	5.4/7.0	
	126 ~ 131	PT4207-09*	6.5	
132 ~ 200	PT4207-09*	6.5		
40	13 ~ 18	PT10507-25	8.5	
	19 ~ 25	PT9415-25 PT9415-15	8.0	
	26 ~ 38	PT8407-25 PT8407-15	6.2	
	39 ~ 57	PT7315-25 PT7315-15	6.2	
	58 ~ 70	PT6307-25 PT6307-15	6.2	
	71 ~ 81	PT6307-25* PT6307-15*	6.2	
	82 ~ 114	PT6307-15* PT6307-09*	6.2/7.0	
	115 ~ 125	PT5215-15* PT5215-09*	5.4/7.0	
	126 ~ 200	PT5215-09*	7.0	
50	16 ~ 22	PT10507-25	8.5	
	23 ~ 32	PT9415-25 PT9415-15	8.0	
	33 ~ 49	PT8407-25 PT8407-15	6.2	
	50 ~ 70	PT7315-25 PT7315-15	6.2	
	71 ~ 74	PT7315-25 PT7315-15	6.2	
	75 ~ 125	PT6307-15* PT7315-09*	6.2/7.0	
	126 ~ 163	PT7315-09*	7.0	
	164 ~ 200	PT6307-09*	7.0	
	60	19 ~ 27	PT10507-25	8.5
28 ~ 39		PT9415-25 PT9415-15	8.0	
40 ~ 60		PT8407-25 PT8407-15	6.2	
61 ~ 70		PT7315-25* PT7315-15*	6.2	
71 ~ 120		PT7315-15* PT7315-09*	6.2/7.0	
121 ~ 131		PT7315-09*	7.0	
132 ~ 200		PT7315-09*	7.0	
75		24 ~ 34	PT10507-25	8.5
		35 ~ 50	PT9415-25 PT9415-15	8.0
	51 ~ 70	PT8407-25 PT8407-15	6.2	
	71 ~ 78	PT8407-15*	6.2	
	79 ~ 120	PT7315-15* PT7315-09*	6.2/7.0	
	121 ~ 200	PT7315-09*	7.0	
	100	32 ~ 46	PT10507-25	8.5
47 ~ 69		PT9415-25* PT9415-15*	8.0	
70 ~ 120		PT8407-15*	6.2	
121 ~ 123		PT7315-09*	7.0	
124 ~ 200		PT7315-09*	7.0	
125	41 ~ 59	PT10507-25	8.5	
	60 ~ 70	PT9415-25* PT9415-15*	8.0	
	71 ~ 90	PT9415-15*	8.0	
	91 ~ 123	PT8407-15*	6.2	
150	50 ~ 70	PT10507-25	8.5	
	71 ~ 78	PT10507-25*	8.5	
	79 ~ 120	PT9415-15	8.0	

CLASS II SERVICE

HP	OUTPUT RPM	REDUCER SELECTION	MINIMUM SHEAVE DIA.
0.25	5 ~ 70	PT1107-25 PT1107-15	3.0
	71 ~ 85	PT1107-25 PT1107-15	3.0
	86 ~ 115	PT1107-15 PT1107-09	3.0/4.0
	116 ~ 140	PT1107-15 PT1107-09	3.0/4.0
	141 ~ 200	PT1107-09	4.0
0.33	4 ~ 6	PT2115-25	3.0
	7 ~ 70	PT1107-25 PT1107-15	3.0
	71 ~ 85	PT1107-25 PT1107-15	3.0
	86 ~ 115	PT1107-15 PT1107-09	3.0/4.0
	116 ~ 140	PT1107-15 PT1107-09	3.0/4.0
	141 ~ 200	PT1107-09	4.0
0.5	4 ~ 5	PT3203-25	4.0
	6 ~ 9	PT2115-25	3.0
	10 ~ 70	PT1107-25 PT1107-15	3.0
	71 ~ 85	PT1107-25 PT1107-15	3.0
	86 ~ 115	PT1107-15 PT1107-09	3.0/4.0
	116 ~ 140	PT1107-15 PT1107-09	3.0/4.0
	141 ~ 200	PT1107-09	4.0
	0.75	4 ~ 5	PT4207-25
6 ~ 8		PT3203-25	4.0
9 ~ 16		PT2115-25	3.0
17 ~ 70		PT1107-25 PT1107-15	3.0
71 ~ 85		PT1107-25 PT1107-15	3.0
86 ~ 115		PT1107-15 PT1107-09	3.0/4.0
116 ~ 140		PT1107-15 PT1107-09	3.0/4.0
1	4 ~ 5	PT4207-25	4.6
	6 ~ 8	PT3203-25	4.0
	9 ~ 16	PT2115-25	3.0
	17 ~ 70	PT1107-25 PT1107-15	3.0
	71 ~ 85	PT1107-25 PT1107-15	3.0
	86 ~ 115	PT1107-15 PT1107-09	3.0/4.0
	116 ~ 140	PT1107-15 PT1107-09	3.0/4.0
	141 ~ 200	PT1107-09	4.0
1.5	5 ~ 7	PT4207-25	4.6
	8 ~ 11	PT3203-25	4.0
	12 ~ 22	PT2115-25	3.0
	23 ~ 70	PT1107-25 PT1107-15	3.0
	71 ~ 85	PT1107-25 PT1107-15	3.0
	86 ~ 115	PT1107-15 PT1107-09	3.0/4.0
	116 ~ 140	PT1107-15 PT1107-09	3.0/4.0
	141 ~ 200	PT1107-09	4.0
2	5 ~ 6	PT5215-25	5.4
	7 ~ 11	PT4207-25	4.6
	12 ~ 18	PT3203-25	4.0
	19 ~ 34	PT2115-25 PT2115-15	3.0
	35 ~ 70	PT1107-25 PT1107-15	3.0
	71 ~ 85	PT1107-25 PT1107-15	3.0
	86 ~ 115	PT1107-15 PT1107-09	3.0/4.0
	116 ~ 140	PT1107-15 PT1107-09	3.0/4.0
	141 ~ 200	PT1107-09	4.0
	3	4 ~ 5	PT6307-25
6 ~ 9		PT5215-25	5.4
10 ~ 14		PT4207-25	4.6
15 ~ 24		PT3203-25 PT3203-15	4.0
25 ~ 47		PT2115-25 PT2115-15	3.0
48 ~ 70		PT1107-25 PT1107-15	3.0
71 ~ 85		PT1107-25 PT1107-15	3.0
86 ~ 115		PT1107-15 PT1107-09	3.0/4.0
116 ~ 140		PT1107-15 PT1107-09	3.0/4.0
141 ~ 200		PT1107-09	4.0

*ADDITIONAL COOLING PROVISIONS MAY BE REQUIRED. CONSULT FACTORY WITH APPLICATION DETAILS.



SELECTION BY INPUT HORSEPOWER

CLASS II SERVICE CONT.

HP	OUTPUT RPM	REDUCER SELECTION		MINIMUM SHEAVE DIA.	
3 (con't)	116 ~ 140	PT1107-15	PT1107-09	3.0/4.0	
	141 ~ 200	PT1107-09		4.0	
5	4 ~ 6	PT8407-25		6.2	
	7 ~ 8	PT7315-25		6.2	
	9 ~ 14	PT6307-25		6.2	
	15 ~ 24	PT5215-25		5.4	
	25 ~ 37	PT4207-25	PT4207-15	4.6	
	38 ~ 69	PT3203-25	PT3203-15	4.0	
	70 ~ 85	PT2115-25	PT2115-15	3.0	
	86 ~ 89	PT2115-15	PT2115-09	3.0/5.0	
	90 ~ 136	PT2115-15	PT2115-09	3.0/5.0	
	137 ~ 140	PT1107-15	PT2115-09	3.0/5.0	
	141 ~ 200	PT1107-09		4.0	
7.5	5	PT9415-25		8.0	
	6 ~ 9	PT8407-25		6.2	
	10 ~ 13	PT7315-25		6.2	
	14 ~ 21	PT6307-25		6.2	
	22 ~ 38	PT5215-25	PT5215-15	5.4	
	39 ~ 59	PT4207-25	PT4207-15	4.6	
	60 ~ 70	PT3203-25	PT3203-15	4.0	
	71 ~ 85	PT3203-25	PT3203-15	4.0	
	86 ~ 110	PT3203-15	PT3203-09	4.0/5.0	
	111 ~ 122	PT2115-15	PT3203-09	3.0/5.0	
	123 ~ 140	PT2115-15	PT3203-09	3.0/5.0	
	141 ~ 183		PT3203-09	5.0	
	184 ~ 200		PT2115-09	5.0	
10	5	PT10507-25		8.5	
	6 ~ 7	PT9415-25		8.0	
	8 ~ 12	PT8407-25		6.2	
	13 ~ 18	PT7315-25		6.2	
	19 ~ 29	PT6307-25	PT6307-15	6.2	
	30 ~ 52	PT5215-25	PT5215-15	5.4	
	53 ~ 70	PT4207-25	PT4207-15	4.6	
	71 ~ 84	PT4207-25	PT4207-15	4.6	
	85 ~ 130	PT3203-15	PT3203-09	4.0/5.0	
	131 ~ 140	PT3203-15	PT3203-09	4.0/5.0	
	141 ~ 200		PT3203-09	5.0	
15	7 ~ 9	PT10507-25		8.5	
	10 ~ 12	PT9415-25		8.0	
	13 ~ 19	PT8407-25		6.2	
	20 ~ 27	PT7315-25		6.2	
	28 ~ 47	PT6307-25	PT6307-15	6.2	
	48 ~ 70	PT5215-25	PT5215-15	5.4	
	71 ~ 82	PT5215-25	PT5215-15	5.4	
	83 ~ 117	PT4207-15	PT4207-09	4.6/6.5	
	118 ~ 140	PT4207-15	PT4207-09	4.6/6.5	
	141 ~ 150		PT4207-09	6.5	
	151 ~ 200		PT3203-09*	5.0	
	20	9 ~ 12	PT10507-25		8.5
		13 ~ 17	PT9415-25		8.0
18 ~ 26		PT8407-25		6.2	
27 ~ 38		PT7315-25	PT7315-15	6.2	
39 ~ 68		PT6307-25	PT6307-15	6.2	
69 ~ 80		PT5215-25	PT5215-15	5.4	
81 ~ 89			PT5215-15	5.4	
91 ~ 117		PT5215-15*	PT5215-09*	5.4/7.0	
118 ~ 125		PT4207-15*	PT4207-09*	4.6/6.5	
126 ~ 200			PT4207-09*	6.5	

HP	OUTPUT RPM	REDUCER SELECTION		MINIMUM SHEAVE DIA.	
25	11 ~ 15	PT10507-25		8.5	
	16 ~ 22	PT9415-25		8.0	
	23 ~ 33	PT8407-25	PT8407-15	6.2	
	34 ~ 49	PT7315-25	PT7315-15	6.2	
	50 ~ 80	PT6307-25	PT6307-15	6.2	
	81 ~ 94	PT6307-15	PT6307-09	6.2/7.0	
	95 ~ 125	PT5215-15*	PT5215-09*	5.4/7.0	
	126 ~ 174		PT5215-09*	7.0	
	175 ~ 200		PT4207-09*	6.5	
	30	13 ~ 19	PT10507-25		8.5
20 ~ 27		PT9415-25	PT9415-15	8.0	
28 ~ 41		PT8407-25	PT8407-15	6.2	
42 ~ 60		PT7315-25	PT7315-15	6.2	
61 ~ 76		PT6307-25	PT6307-15	6.2	
77 ~ 89		PT6307-15	PT6307-09	6.2/7.0	
90 ~ 125		PT6307-15*	PT6307-09*	6.2/7.0	
126 ~ 200			PT5215-09*	7.0	
40		18 ~ 25	PT10507-25		8.5
		26 ~ 36	PT9415-25	PT9415-15	8.0
	37 ~ 56	PT8407-25	PT8407-15	6.2	
	57 ~ 75	PT7315-25	PT7315-15	6.2	
	76 ~ 88		PT7315-15	6.2	
	89 ~ 114	PT6307-15*		6.2	
	115 ~ 120	PT6307-15*	PT6307-09*	6.2/7.0	
	121 ~ 200		PT6307-09*	7.0	
	50	22 ~ 32	PT10507-25		8.5
		33 ~ 46	PT9415-25	PT9415-15	8.0
47 ~ 70		PT8407-25	PT8407-15	6.2	
71 ~ 72		PT8407-25	PT8407-15	6.2	
73 ~ 95			PT7315-15*	6.2	
96 ~ 110		PT7315-15*	PT7315-09	6.2/7.0	
111 ~ 120		PT7315-15*	PT7315-09*	6.2/7.0	
121 ~ 179			PT7315-09*	7.0	
180 ~ 200			PT6307-09*	7.0	
60		27 ~ 39	PT10507-25		8.5
	40 ~ 56	PT9415-25	PT9415-15	8.0	
	57 ~ 70	PT8407-25	PT8407-15	6.2	
	71 ~ 75	PT8407-25	PT8407-15	6.2	
	76 ~ 89		PT8407-15	6.2	
	90 ~ 120	PT7315-15*	PT7315-09*	6.2/7.0	
	121 ~ 200		PT7315-09*	7.0	
	75	34 ~ 49	PT10507-25		8.5
		50 ~ 73	PT9415-25	PT9415-15	8.0
		74 ~ 75	PT8407-25	PT8407-15	6.2
76 ~ 120			PT8407-15*	6.2	
121 ~ 133			PT7315-09*	7.0	
134 ~ 200			PT7315-09*	7.0	
100		46 ~ 67	PT10507-25		8.5
		68 ~ 75	PT9415-25*	PT9415-15*	8.0
		76 ~ 103		PT9415-15*	8.0
		104 ~ 120		PT8407-15*	6.2
	181 ~ 200		PT7315-09*	7.0	
	125	59 ~ 79	PT10507-25*		8.5
80 ~ 120			PT9415-15*	8.0	
150	73 ~ 75	PT10507-25*		8.5	

*ADDITIONAL COOLING PROVISIONS MAY BE REQUIRED. CONSULT FACTORY WITH APPLICATION DETAILS.



SELECTION BY INPUT HORSEPOWER CLASS III SERVICE

HP	OUTPUT RPM	REDUCER SELECTION	MINIMUM SHEAVE DIA.
0.25	4 ~ 6	PT2115-25	3.0
	7 ~ 70	PT1107-25 PT1107-15	3.0
	71 ~ 85	PT1107-25 PT1107-15	3.0
	86 ~ 89	PT1107-15 PT1107-09	3.0/4.0
	90 ~ 115	PT1107-15 PT1107-09	3.0/4.0
	116 ~ 140	PT1107-15 PT1107-09	3.0/4.0
	141 ~ 200	PT1107-09	4.0
0.33	5 ~ 9	PT2115-25	3.0
	10 ~ 70	PT1107-25 PT1107-15	3.0
	71 ~ 85	PT1107-25 PT1107-15	3.0
	86 ~ 115	PT1107-15 PT1107-09	3.0/4.0
	116 ~ 140	PT1107-15 PT1107-09	3.0/4.0
0.50	4 ~ 5	PT4207-25	4.6
	6 ~ 7	PT3203-25	4.0
	8 ~ 15	PT2115-25	3.0
	16 ~ 70	PT1107-25 PT1107-15	3.0
	71 ~ 85	PT1107-25 PT1107-15	3.0
	86 ~ 115	PT1107-15 PT1107-09	3.0/4.0
	116 ~ 140	PT1107-15 PT1107-09	3.0/4.0
	141 ~ 200	PT1107-09	4.0
0.75	4	PT5215-25	5.4
	5 ~ 7	PT4207-25	4.6
	8 ~ 12	PT3203-25	4.0
	13 ~ 23	PT2115-25	3.0
	24 ~ 70	PT1107-25 PT1107-15	3.0
	71 ~ 85	PT1107-25 PT1107-15	3.0
	86 ~ 115	PT1107-15 PT1107-09	3.0/4.0
	116 ~ 140	PT1107-15 PT1107-09	3.0/4.0
1.00	4 ~ 6	PT5215-25	5.4
	7 ~ 10	PT4207-25	4.6
	11 ~ 17	PT3203-25	4.0
	18 ~ 32	PT2115-25	3.0
	33 ~ 70	PT1107-25 PT1107-15	3.0
	71 ~ 85	PT1107-25 PT1107-15	3.0
	86 ~ 115	PT1107-15 PT1107-09	3.0/4.0
	116 ~ 140	PT1107-15 PT1107-09	3.0/4.0
1.5	4 ~ 5	PT6307-25	6.2
	6 ~ 10	PT5215-25	5.4
	11 ~ 15	PT4207-25	4.6
	16 ~ 26	PT3203-25	4.0
	27 ~ 51	PT2115-25 PT2115-15	3.0
	52 ~ 70	PT1107-25 PT1107-15	3.0
	71 ~ 85	PT1107-25 PT1107-15	3.0
	86 ~ 115	PT1107-15 PT1107-09	3.0/4.0
	116 ~ 140	PT1107-15 PT1107-09	3.0/4.0
	141 ~ 200	PT1107-09	4.0

HP	OUTPUT RPM	REDUCER SELECTION	MINIMUM SHEAVE DIA.
2	5 ~ 7	PT6307-25	6.2
	8 ~ 13	PT5215-25	5.4
	14 ~ 21	PT4207-25	4.6
	22 ~ 36	PT3203-25 PT3203-15	4.0
	37 ~ 71	PT2115-25 PT2115-15	3.0
	72 ~ 85	PT1107-25 PT1107-15	3.0
	86 ~ 115	PT1107-15 PT1107-09	3.0/4.0
	116 ~ 140	PT1107-15 PT1107-09	3.0/4.0
	141 ~ 200	PT1107-09	4.0
3	4 ~ 5	PT8407-25	6.2
	6 ~ 7	PT7315-25	6.2
	8 ~ 12	PT6307-25	6.2
	13 ~ 20	PT5215-25	5.4
	21 ~ 32	PT4207-25 PT4207-15	4.6
	33 ~ 57	PT3203-25 PT3203-15	4.0
	58 ~ 70	PT2115-25 PT2115-15	3.0
	71 ~ 85	PT2115-25 PT2115-15	3.0
	86 ~ 89	PT2115-15 PT2115-09	3.0/5.0
	90 ~ 113	PT2115-15 PT2115-09	3.0/5.0
5	114 ~ 140	PT1107-15 PT1107-09	3.0/4.0
	141 ~ 200	PT1107-09	4.0
	5	PT9415-25	8.0
	6 ~ 8	PT8407-25	6.2
	9 ~ 12	PT7315-25	6.2
	13 ~ 20	PT6307-25	6.2
	21 ~ 36	PT5215-25 PT5215-15	5.4
	37 ~ 56	PT4207-25 PT4207-15	4.6
	57 ~ 70	PT3203-25 PT3203-15	4.0
	71 ~ 85	PT3203-25 PT3203-15	4.0
7.5	86 ~ 103	PT3203-15 PT3203-09	4.0/5.0
	104 ~ 114	PT2115-15 PT3203-09	3.0/5.0
	115 ~ 140	PT2115-15 PT2115-09	3.0/5.0
	141 ~ 167	PT2115-09	5.0
	168 ~ 200	PT2115-09	5.0
	5 ~ 6	PT10507-25	8.5
	7 ~ 8	PT9415-25	8.0
	9 ~ 13	PT8407-25	6.2
	14 ~ 19	PT7315-25	6.2
	20 ~ 32	PT6307-25 PT6307-15	6.2
1.5	33 ~ 56	PT5215-25 PT5215-15	5.4
	57 ~ 70	PT4207-25 PT4207-15	4.6
	71 ~ 85	PT4207-25 PT4207-15	4.6
	86 ~ 93	PT4207-15 PT4207-09	4.6/6.5
	94 ~ 140	PT3203-15 PT3203-09	4.0/5.0
	141 ~ 144	PT3203-09	5.0
	145 ~ 200	PT3203-09	5.0

*ADDITIONAL COOLING PROVISIONS MAY BE REQUIRED. CONSULT FACTORY WITH APPLICATION DETAILS.



SELECTION BY INPUT HORSEPOWER

CLASS III SERVICE CONT.

HP	OUTPUT RPM	REDUCER SELECTION	MINIMUM SHEAVE DIA.
10	7 ~ 8	PT10507-25	8.5
	9 ~ 12	PT9415-25	8.0
	13 ~ 18	PT8407-25	6.2
	19 ~ 26	PT7315-25 PT7315-15	6.2
	27 ~ 45	PT6307-25 PT6307-15	6.2
	46 ~ 70	PT5215-25 PT5215-15	5.4
	71 ~ 78	PT5215-25 PT5215-15	5.4
	79 ~ 92	PT4207-15	4.6
	93 ~ 105	PT4207-15 PT4207-09	4.6/6.5
	106 ~ 141	PT4207-15 PT4207-09	4.6/6.5
	142 ~ 200	PT3203-09	5.0
15	10 ~ 13	PT10507-25	8.5
	14 ~ 19	PT9415-25	8.0
	20 ~ 28	PT8407-25 PT8407-15	6.2
	29 ~ 41	PT7315-25 PT7315-15	6.2
	42 ~ 70	PT6307-25 PT6307-15	6.2
	71 ~ 75	PT6307-25 PT6307-15	6.2
	76 ~ 93	PT5215-15	5.4
	94 ~ 115	PT5215-15 PT5215-09	5.4/7.0
	116 ~ 125	PT5215-15 PT5215-09	5.4/7.0
	126 ~ 131	PT5215-09	7.0
	132 ~ 200	PT4207-09	6.5
20	13 ~ 18	PT10507-25	8.5
	19 ~ 25	PT9415-25 PT9415-15	8.0
	26 ~ 38	PT8407-25 PT8407-15	6.2
	39 ~ 57	PT7315-25 PT7315-15	6.2
	58 ~ 70	PT6307-25 PT6307-15	6.2
	71 ~ 114	PT6307-15 PT6307-09	6.2/7.0
	115 ~ 125	PT5215-15* PT5215-09*	5.4/7.0
	126 ~ 200	PT5215-09*	7.0
25	16 ~ 22	PT10507-25	8.5
	23 ~ 32	PT9415-25 PT9415-15	8.0
	33 ~ 49	PT8407-25 PT8407-15	6.2
	50 ~ 70	PT7315-25 PT7315-15	6.2
	71 ~ 74	PT7315-25 PT7315-15	6.2
	75 ~ 104	PT6307-15	6.2
	105 ~ 113	PT6307-15* PT6307-09	6.2/7.0
	114 ~ 125	PT6307-15* PT6307-09*	6.2/7.0
126 ~ 200	PT6307-09*	7.0	
30	19 ~ 27	PT10507-25	8.5
	28 ~ 39	PT9415-25 PT9415-15	8.0
	40 ~ 60	PT8407-25 PT8407-15	6.2
	61 ~ 70	PT7315-25 PT7315-15	6.2
	71 ~ 98	PT7315-15	6.2
	99 ~ 125	PT6307-15	6.2
	126 ~ 131	PT6307-09*	7.0
	132 ~ 200	PT6307-09*	7.0

HP	OUTPUT RPM	REDUCER SELECTION	MINIMUM SHEAVE DIA.
40	26 ~ 37	PT10507-25	8.5
	38 ~ 53	PT9415-25 PT9415-15	8.0
	54 ~ 70	PT8407-25 PT8407-15	6.2
	71 ~ 84	PT8407-15	6.2
	85 ~ 89	PT7315-15 PT7315-09	6.2/7.0
	90 ~ 120	PT7315-15* PT7315-09	6.2/7.0
	121 ~ 200	PT7315-09*	7.0
50	32 ~ 46	PT10507-25	8.5
	47 ~ 69	PT9415-25 PT9415-15	8.0
	70 ~ 75	PT8407-25 PT8407-15	6.2
	76 ~ 110	PT8407-15	6.2
	111 ~ 120	PT7315-15* PT7315-09*	6.2/7.0
	121 ~ 123	PT7315-09*	7.0
60	39 ~ 56	PT10507-25	8.5
	57 ~ 75	PT9415-25 PT9415-15	8.0
	76 ~ 85	PT9415-15	8.0
	86 ~ 115	PT8407-15	6.2
	142 ~ 161	PT7315-09*	7.0
	162 ~ 200	PT7315-09*	7.0
	75	50 ~ 72	PT10507-25
73 ~ 75		PT9415-25* PT9415-15*	8.0
76 ~ 120		PT9415-15*	8.0

*ADDITIONAL COOLING PROVISIONS MAY BE REQUIRED. CONSULT FACTORY WITH APPLICATION DETAILS.



MECHANICAL RATINGS

INPUT HORSEPOWER AND OUTPUT TORQUE, 1.00 SERVICE FACTOR

9/1 NOMINAL RATIO

OUTPUT RPM	PT1107		PT2115		PT3203		PT4207	
	ACTUAL RATIO 8.92:1		ACTUAL RATIO 9.25:1		ACTUAL RATIO 8.91:1		ACTUAL RATIO 9.68:1	
	INPUT HP	OUTPUT TORQUE (IN-LB)	INPUT HP	OUTPUT TORQUE (IN-LB)	INPUT HP	OUTPUT TORQUE (IN-LB)	INPUT HP	OUTPUT TORQUE (IN-LB)
200	9.1	2753	11.6	3494	30.1	9118	45.0	13598
190	8.8	2802	11.0	3503	28.7	9133	42.7	13604
180	8.5	2857	10.4	3503	27.2	9150	40.6	13630
170	8.3	2954	9.9	3506	25.8	9165	38.3	13635
160	8.0	3025	9.3	3513	24.3	9178	36.1	13663
150	7.6	3066	8.7	3517	22.8	9193	33.9	13666
140	7.2	3112	8.1	3518	21.3	9205	31.7	13700
120	6.4	3227	7.0	3529	18.3	9247	27.3	13739
100	5.6	3388	5.9	3539	15.3	9281	22.8	13783

15/1 NOMINAL RATIO

OUTPUT RPM	PT1107		PT2115		PT3203		PT4207		PT5215	
	ACTUAL RATIO 15.35:1		ACTUAL RATIO 14.10:1		ACTUAL RATIO 14.88:1		ACTUAL RATIO 15.13:1		ACTUAL RATIO 15.40:1	
	INPUT HP	OUTPUT TORQUE (IN-LB)	INPUT HP	OUTPUT TORQUE (IN-LB)	INPUT HP	OUTPUT TORQUE (IN-LB)	INPUT HP	OUTPUT TORQUE (IN-LB)	INPUT HP	OUTPUT TORQUE (IN-LB)
140	7.5	3220	11.6	5013	19.7	8496	31.8	13743		
130	7.0	3235	11.0	5124	18.7	8689	30.2	14051	44.0	20464
120	6.5	3252	10.4	5249	17.7	8899	28.6	14395	41.6	20955
100	5.4	3291	9.2	5548	15.5	9402	25.1	15205	36.6	22132
80	4.4	3343	7.8	5929	13.3	10051	20.5	15497	31.3	23657
60	3.4	3398	6.4	6464	10.5	10558	15.7	15822	25.6	25805
40	2.3	3479	4.8	7306	7.2	10891	10.7	16215	18.2	27529
30	1.7	3509	3.9	7765	5.4	10951	8.2	16457	13.9	27973
20	1.2	3570	2.6	7896	3.7	11133	5.5	16760	9.6	28891

25/1 NOMINAL RATIO

OUTPUT RPM	PT1107		PT2115		PT3203		PT4207		PT5215	
	ACTUAL RATIO 23.93:1		ACTUAL RATIO 23.46:1		ACTUAL RATIO 24.71:1		ACTUAL RATIO 24.38:1		ACTUAL RATIO 25.56:1	
	INPUT HP	OUTPUT TORQUE (IN-LB)	INPUT HP	OUTPUT TORQUE (IN-LB)	INPUT HP	OUTPUT TORQUE (IN-LB)	INPUT HP	OUTPUT TORQUE (IN-LB)	INPUT HP	OUTPUT TORQUE (IN-LB)
85	4.7	3310	8.1	5787	14.2	10093	21.5	15332	32.6	23234
75	4.2	3348	7.5	6067	12.7	10245	19.3	15570	29.9	24121
65	3.7	3398	6.8	6339	11.2	10416	17.0	15824	27.1	25179
55	3.1	3454	6.1	6655	9.6	10594	14.7	16116	24.1	26468
45	2.6	3496	5.2	7018	8.0	10810	12.2	16457	20.2	27133
35	2.1	3578	4.2	7174	6.4	11029	9.7	16837	16.1	27797
25	1.5	3654	3.0	7357	4.6	11205	7.2	17328	11.8	28630
15	0.94	3792	1.9	7543	2.8	11415	4.4	17788	7.3	29244
5	0.32	3872	0.65	7866	1.0	11617	1.5	18030	2.5	30131



MECHANICAL RATINGS

INPUT HORSEPOWER AND OUTPUT TORQUE, 1.00 SERVICE FACTOR

9/1 NOMINAL RATIO

OUTPUT RPM	PT5215		PT6307		PT7315	
	ACTUAL RATIO 8.96:1		ACTUAL RATIO 9.21:1		ACTUAL RATIO 9.62:1	
	INPUT HP	OUTPUT TORQUE (IN-LB)	INPUT HP	OUTPUT TORQUE (IN-LB)	INPUT HP	OUTPUT TORQUE (IN-LB)
200	68.0	20577	95.3	28839	151	45535
190	64.7	20594	90.7	28895	145	46066
180	61.4	20642	86.0	28914	139	46605
170	58.1	20664	81.4	28978	132	47150
160	54.7	20681	76.7	28997	126	47700
150	51.3	20700	72.1	29066	119	48173
140	48.0	20762	67.3	29085	114	49423
120	41.3	20803	57.9	29183	99.8	50339
100	34.6	20904	48.4	29290	84.8	51313

15/1 NOMINAL RATIO

OUTPUT RPM	PT6307		PT7315		PT8407		PT9415	
	ACTUAL RATIO 15.33:1		ACTUAL RATIO 15.23:1		ACTUAL RATIO 15.08:1		ACTUAL RATIO 15.12:1	
	INPUT HP	OUTPUT TORQUE (IN-LB)	INPUT HP	OUTPUT TORQUE (IN-LB)	INPUT HP	OUTPUT TORQUE (IN-LB)	INPUT HP	OUTPUT TORQUE (IN-LB)
140								
130	82.9	38583						
120	77.1	38894	100	50596	163	82270	236	118795
100	65.4	39576	88.4	53473	139	83883	200	121208
80	53.4	40364	75.7	57222	113	85711	164	124018
60	41.0	41294	60.3	60756	87.2	87973	126.3	127391
40	28.1	42444	41.4	62561	60.0	90741	87.0	131626
30	21.4	43180	31.6	63711	45.9	92490	66.6	134258
20	15.0	45227	21.5	65072	31.3	94628	45.5	137526

25/1 NOMINAL RATIO

OUTPUT RPM	PT6307		PT7315		PT8407		PT9415		PT10507	
	ACTUAL RATIO 25.13:1		ACTUAL RATIO 24.59:1		ACTUAL RATIO 24.62:1		ACTUAL RATIO 25.97:1		ACTUAL RATIO 24.30:1	
	INPUT HP	OUTPUT TORQUE (IN-LB)	INPUT HP	OUTPUT TORQUE (IN-LB)	INPUT HP	OUTPUT TORQUE (IN-LB)	INPUT HP	OUTPUT TORQUE (IN-LB)	INPUT HP	OUTPUT TORQUE (IN-LB)
85	56.0	39890								
75	50.3	40578	72.1	58197	105	84706	155	124800	216	174252
65	44.4	41338	63.7	59331	94.4	87908	135.8	126425	193.2	179827
55	38.4	42188	55.1	60614	81.8	90008	116.6	128290	166.0	182590
45	32.1	43160	45.2	60706	68.2	91697	97.0	130460	138.2	185801
35	25.6	44306	36.4	62838	53.4	92260	76.9	132867	109.5	189343
25	18.9	45620	26.2	63408	38.5	93128	56.1	135795	80.1	193831
15	11.8	47395	16.0	64699	23.6	94991	34.6	139563	49.5	199542
5	4.0	48282	5.4	65223	8.5	102252	12.0	145452	17.2	208497





DIMENSIONS

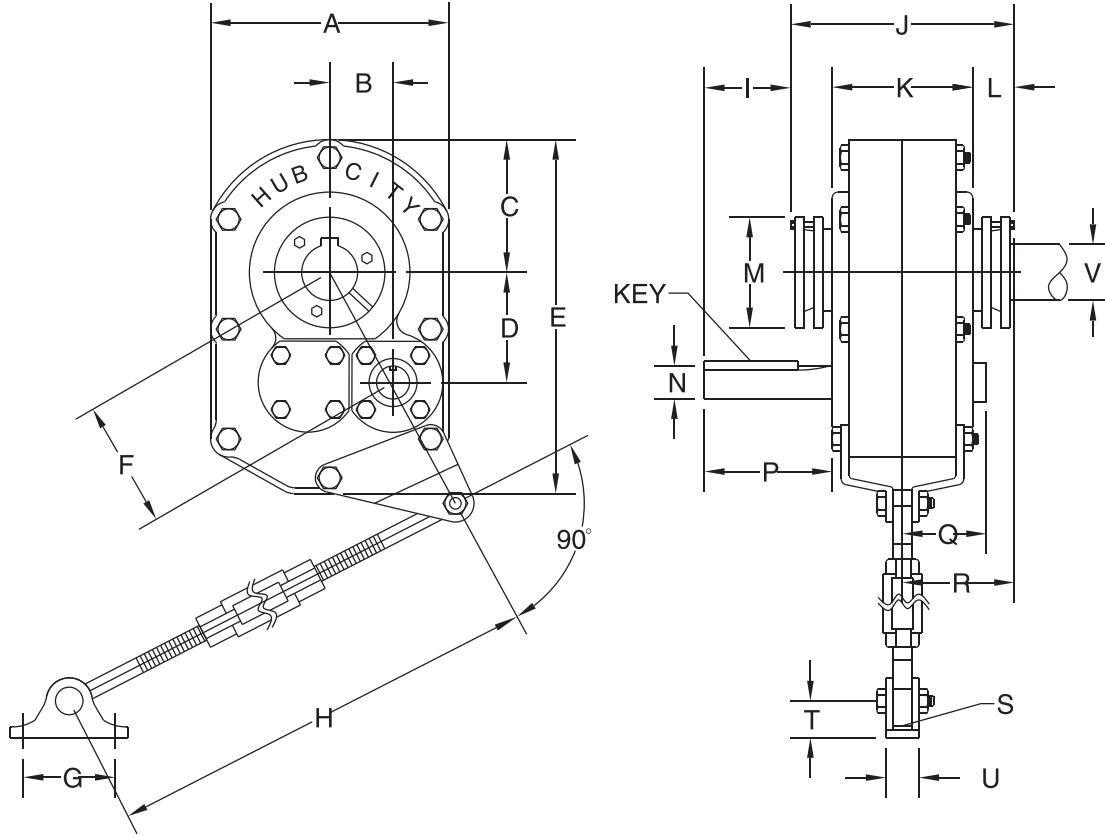

MODEL	A	B	C	D	E	F	G	H MIN/MAX	I	J	K
PT1107	7.13	1.91	3.75	3.18	9.94	3.71	2.50	23.81/29.63	2.03	7.06	4.06
PT2115	8.38	2.14	4.09	3.75	11.41	4.32	3.00	26.94/32.94	2.22	7.32	4.50
PT3203	9.25	2.33	4.84	4.17	12.88	4.78	3.00	26.94/32.94	2.34	9.22	5.63
PT4207	10.38	2.76	5.50	4.79	15.13	5.53	4.00	29.19/35.14	3.44	9.98	6.13
PT5215	13.13	3.04	6.56	5.67	18.31	6.43	4.00	29.19/35.19	3.44	10.52	6.31
PT6307	15.43	4.09	7.56	6.73	21.31	7.88	4.75	29.19/35.19	3.73	11.53	6.88
PT7315	18.75	5.11	9.38	8.30	25.94	9.74	4.75	29.44/35.44	3.75	12.85	7.75
PT8407	20.25	6.03	10.13	9.50	28.25	11.25	7.00	30.00/36.00	4.31	14.03	8.37
PT9415	22.63	6.59	11.31	10.81	31.69	12.66	7.00	30.00/36.00	3.63	14.12	8.12
PT10507	25.50	6.59	12.75	12.50	35.08	14.13	7.00	30.00/36.00	6.53	15.30	9.34

MODEL	L	M	Q	R	S	T	U	V MAX DIA	INPUT SHAFT			APPROX. WEIGHT (LB)
									N DIA	P	KEY	
PT1107	1.30	3.25	2.67	3.55	.38	.94	1.06	1-7/16	0.75	3.30	3/16x3/16x1-7/8	45
PT2115	1.40	4.06	2.89	3.68	0.44	1.06	1.25	1 15/16	1.13	3.59	1/4x1/4x2-1/2	58
PT3203	1.59	4.38	3.30	3.72	0.44	1.06	1.25	2 3/16	1.25	4.34	1/4x1/4x2-7/8	98
PT4207	1.72	4.81	3.41	3.91	0.50	1.75	1.44	2 7/16	1.44	5.57	3/8x3/8x4-1/16	139
PT5215	1.91	5.63	4.45	5.05	0.50	1.75	1.44	2 15/16	1.94	5.74	1/2x1/2x4-1/2	207
PT6307	2.30	6.13	4.57	5.73	0.63	2.00	2.75	3 7/16	2.19	6.08	1/2x1/2x4-1/2	285
PT7315	2.50	7.25	4.69	6.38	0.63	2.00	2.75	3 15/16	2.44	6.35	5/8x5/8x4-3/4	462
PT8407	2.86	7.75	5.85	7.04	0.75	3.13	4.00	4 7/16	2.44	7.11	5/8x5/8x5-3/8	633
PT9415	2.98	8.75	5.66	7.04	0.75	3.13	4.00	4 5/16	2.44	9.65	5/8x5/8x7-3/4	760
PT10507	2.99	10.13	6.96	7.66	0.75	3.13	4.00	5 7/16	2.69	9.50	5/8x5/8x7-7/8	1020

FOR LUBRICATION AND INSTALLATION INSTRUCTIONS REFER TO SECTION R.



POWERTORQUE® ACCESSORIES

TAPERED BUSHING KITS

Flanged bushing mount
 Removal screws allow for easy demounting
 Ductile iron material for shock resistance
 Clamp fit, no setscrews
 Split design eliminates seizing problems
 Kits include two bushings, key and mounting hardware

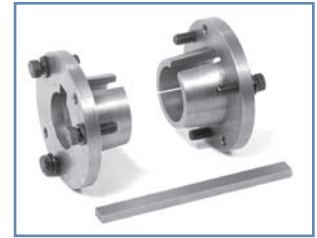

SHAFT MOUNT MODEL	BORE SIZE	PART NUMBER	WEIGHT (LBS.)	SHAFT MOUNT MODEL	BORE SIZE	PART NUMBER	WEIGHT (LBS.)
PT1107	1-7/16	0279-00001	2.8	PT6307	3-7/16	0279-00076	9
	1-3/8	0279-00002	2.9		3	0279-00077	11.4
	1-5/16	0279-00003	2.9		2-15/16	0279-00078	11.7
	1-1/4	0279-00004	3.0		2-7/16	0279-00082	12.4
PT2115	1-15/16	0279-00016	3	PT7315	3-15/16	0279-00091	12.9
	1-3/4	0279-00017	3.4		3-7/16	0279-00092	13.9
	1-11/16	0279-00018	3.5		3-3/16	0279-00093	16.8
	1-5/8	0279-00019	3.6		3	0279-00094	19.2
PT3203	2-3/16	0279-00031	3.7	PT8407	4-7/16	0279-00106	15.1
	2	0279-00032	4.3		4-3/16	0279-00107	17.4
	1-15/16	0279-00033	4.6		3-15/16	0279-00108	20.2
	1-7/8	0279-00034	4.8		3-7/16	0279-00109	25.6
PT4207	2-7/16	0279-00046	5.9	PT9415	4-15/16	0279-00120	25
	2-1/4	0279-00047	6.4		4-7/16	0279-00121	27
	2-3/16	0279-00048	6.8		3-15/16	0279-00122	28
	2-1/8	0279-00049	7.1		3-7/16	0279-00123	30
PT5215	2-15/16	0279-00061	7.8	PT10507	5-7/16	0279-00136	28
	2-11/16	0279-00062	7.9		4-15/16	0279-00137	33
	2-1/2	0279-00063	8.5		4-7/16	0279-00138	36
	2-7/16	0279-00064	8.6		3-15/16	0279-00139	40

BACKSTOP KITS

Quick installation on input shaft
 Internally installed, sealed from contamination
 Lubricated by internal gear lubricant
 Designed to operate in either direction



G

SHAFT MOUNT MODEL	PART NUMBER	WEIGHT (LBS.)
PT1107 & PT2115	0279-00166	1
PT2115*	0279-00167	1
PT3203	0279-00168	1.1
PT4207	0279-00169	1.2
PT5215	0279-00170	2.2
PT6307	0279-00171	2.5
PT7315	0279-00172	2.8
PT8407 & PT9415	0279-00173	3.8
PT10507	0279-00175	6

* USE FOR PT2115 WITHOUT END CAPS (BALL BEARING)



POWERTORQUE® ACCESSORIES VERTICAL MOTOR MOUNTS

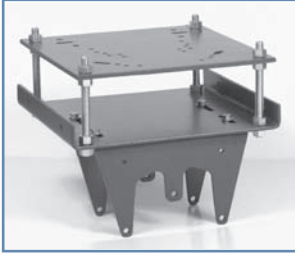

All-Steel construction for rigidity
Compact design eliminates need for motor base
Top plate adjusts for easy tensioning of drive belt
Mounting holes provided match NEMA standards

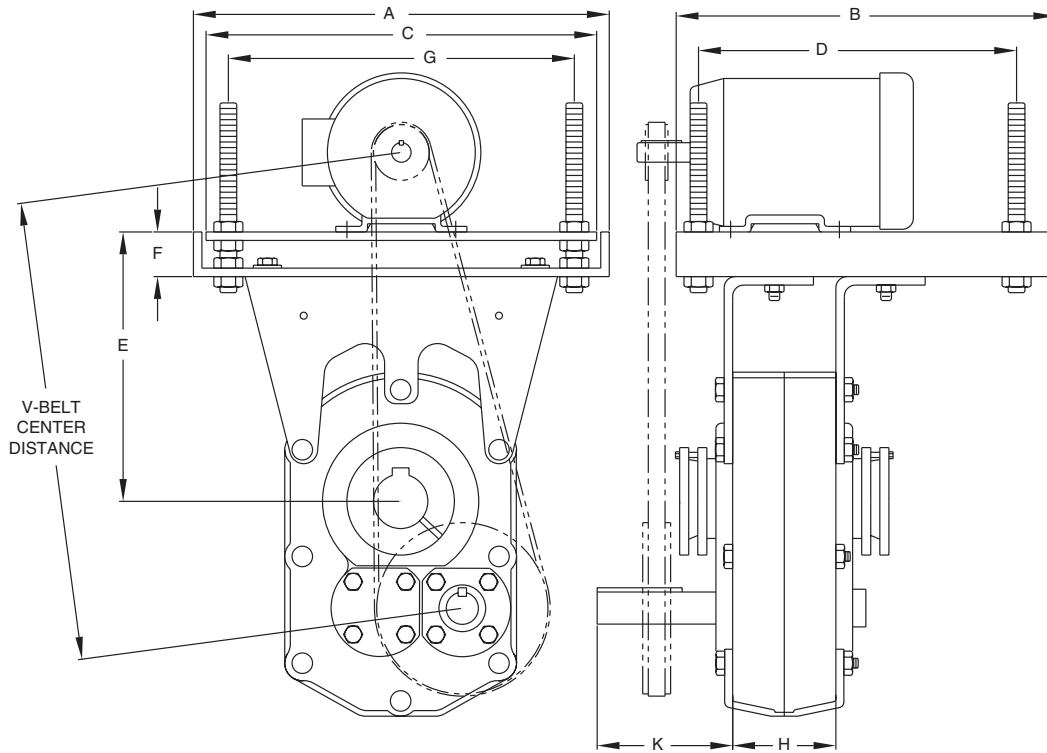

NOTE: SHIELDS/GUARDS NOT SHOWN FOR ILLUSTRATION PURPOSES



POWERTORQUE® ACCESSORIES

VERTICAL MOTOR MOUNTS

VERTICAL MOTOR MOUNTS			V-BELT CENTER DISTANCE FOR NEMA MOTOR FRAMES													
SHAFT MOUNT	PART NUMBER	NEMA MOTOR	56-140 MIN	56-140 MAX	180 MIN	180 MAX	210 MIN	210 MAX	250 MIN	250 MAX	280 MIN	280 MAX	320 MIN	320 MAX	360 MIN	360 MAX
PT1107	0279-00180	56C-215T	17.6	21.0	18.5	22.0	19.3	22.7								
PT2115	0279-00181	56C-215T	18.7	22.1	19.7	23.1	20.5	23.9								
PT3203	0279-00182	56C-215T	20.2	23.6	21.2	24.6	22.0	25.3								
PT3203	0279-00183	143T-286T	20.4	23.8	21.4	24.8	22.2	25.5	23.2	26.5	23.9	27.2				
PT4207	0279-00184	143T-286T	21.2	25.2	22.2	26.2	23.0	26.9	23.9	27.9	24.7	28.7				
PT4207	0279-00189	143T-326T	21.3	25.3	22.3	26.3	23.1	27.0	24.0	28.0	24.8	28.8	25.8	29.8		
PT5215	0279-00185	143T-286T	22.7	26.6	23.7	27.6	24.4	28.4	25.4	29.4	26.2	30.1				
PT5215	0279-00186	143T-326T	22.8	26.7	23.8	27.7	24.5	28.5	25.5	29.5	26.3	30.2	27.3	31.2		
PT6307	0279-00187	143T-326T	25.9	29.7	26.9	30.7	31.4	37.6	28.6	32.4	29.4	33.2	30.4	34.2		
PT7315	0279-00188	143T-365T	30.6	34.4	31.6	35.4	32.4	36.2	33.4	37.2	34.1	37.9	35.1	38.9	36.1	39.9
PT8407	0279-00190	143T-365T	31.9	36.4	32.9	37.4	33.7	38.2	34.7	39.2	35.4	39.9	36.4	40.9	37.4	41.9
PT9415	0279-00191	143T-365T	32.0	35.8	33.0	36.8	33.8	37.6	34.8	38.6	32.8	39.3	36.5	40.3	37.5	41.4
PT10507	0279-00193	143T-365T	33.5	37.3	34.5	38.3	35.3	39.1	36.3	40.1	34.3	40.8	38.0	41.8	39.0	42.9

SHAFT MOUNT	PART NUMBER	WEIGHT (LBS.)	A	B	C	D	E		F	G	H	J	K
							MIN	MAX					
PT1107	0279-00180	35	14.63	11.00	13.50	9.25	10.0	14.2	1.59	12.00	3.38	5/8x7	3.88
PT2115	0279-00181	35	14.63	11.00	13.50	9.25	10.6	14.8	1.59	12.00	3.38	5/8x7	4.18
PT3203	0279-00182	35	14.63	11.00	13.50	9.25	11.6	15.9	1.59	12.00	4.25	5/8x8	4.88
PT3203	0279-00183	77	18.63	17.00	17.50	14.25	11.8	16.0	1.78	15.50	4.25	3/4x8	4.88
PT4207	0279-00184	87	18.63	17.00	17.50	14.25	12.0	16.7	1.78	15.50	4.63	3/4x8	6.13
PT4207	0279-00189	121	20.50	18.50	19.25	16.50	12.0	16.8	1.84	17.50	4.63	3/4x8	6.13
PT5215	0279-00185	84	18.63	17.00	17.50	14.25	12.5	17.3	1.78	15.50	4.13	3/4x8	6.65
PT5215	0279-00186	118	20.50	18.50	19.25	16.50	12.5	17.3	1.84	17.50	4.13	3/4x8	6.65
PT6307	0279-00187	118	20.50	18.50	19.25	16.50	14.6	19.3	1.84	17.50	4.50	3/4x8	7.31
PT7315	0279-00188	148	22.50	19.00	21.25	16.50	17.6	22.1	2.50	19.25	4.75	1x9	7.81
PT8407	0279-00190	148	22.50	19.00	21.25	16.50	18.3	22.8	2.50	19.25	4.75	1x9	8.81
PT9415	0279-00191	125	22.50	19.00	21.25	16.50	19.0	23.5	2.50	19.25	5.40	1x9	11.08
PT10507	0279-00193	135	22.50	19.00	21.25	16.50	20.5	25.0	2.50	19.25	6.18	1x9	11.15

VERTICAL LONG MOTOR MOUNTS

VERTICAL LONG MOTOR MOUNTS			V-BELT CENTER DISTANCE FOR NEMA MOTOR FRAMES													
SHAFT MOUNT	PART NUMBER	NEMA MOTOR	56-140 MIN	56-140 MAX	180 MIN	180 MAX	210 MIN	210 MAX	250 MIN	250 MAX	280 MIN	280 MAX	320 MIN	320 MAX	360 MIN	360 MAX
PT1107	0279-00196	56C-215T	20.6	24.0	21.5	25.0	22.3	25.7								
PT2115	0279-00197	56C-215T	21.7	25.1	22.7	26.1	23.5	26.9								
PT3203	0279-00198	56C-215T	23.2	26.6	24.2	27.6	25.0	28.3								
PT3203	0279-00199	143T-286T	23.4	26.8	24.4	27.8	25.2	28.5	26.2	29.5	26.9	30.2				
PT4207	0279-00200	143T-286T	25.7	29.7	26.7	30.7	27.5	31.4	28.4	32.4	29.2	33.2				
PT4207	0279-00201	143T-326T	25.8	29.8	26.8	30.8	27.6	31.5	28.5	32.5	29.3	33.3	30.3	34.3		
PT5215	0279-00202	143T-286T	29.5	33.4	30.5	34.4	31.2	35.2	32.2	36.2	33.0	36.9				
PT5215	0279-00203	143T-326T	29.5	33.4	30.5	34.4	31.2	35.2	32.2	36.2	33.0	36.9	34.0	37.9		
PT6307	0279-00204	143T-326T	39.9	43.7	40.9	44.7	45.4	51.6	42.6	46.4	43.4	47.2	44.4	48.2		
PT7315	0279-00205	143T-365T	45.6	49.4	46.6	50.4	47.4	51.2	48.4	52.2	49.1	52.9	50.1	53.9	51.1	54.9
PT8407	0279-00206	143T-365T	44.9	49.4	45.9	50.4	46.7	51.2	47.7	52.2	48.4	52.9	49.4	53.9	50.4	54.9

SHAFT MOUNT	PART NUMBER	WEIGHT (LBS.)	A	B	C	D	E		F	G	H	J	K
							MIN	MAX					
PT1107	0279-00196	41	14.63	11.00	13.50	9.25	13.0	17.2	1.59	12.00	3.38	5/8x7	3.88
PT2115	0279-00197	41	14.63	11.00	13.50	9.25	13.6	17.8	1.59	12.00	3.38	5/8x7	4.18
PT3203	0279-00198	41	14.63	11.00	13.50	9.25	14.6	18.8	1.59	12.00	4.25	5/8x8	4.88
PT3203	0279-00199	83	18.63	17.00	17.50	14.25	14.8	19.0	1.78	15.50	4.25	3/4x8	4.88
PT4207	0279-00200	95	18.63	17.00	17.50	14.25	16.5	21.2	1.78	15.50	4.63	3/4x8	6.13
PT4207	0279-00201	129	20.50	18.50	19.25	16.50	16.5	21.3	1.84	17.50	4.63	3/4x8	6.13
PT5215	0279-00202	106	18.63	17.00	17.50	14.25	19.3	24.0	1.78	15.50	4.13	3/4x8	6.65
PT5215	0279-00203	137	20.50	18.50	19.25	16.50	19.3	24.0	1.84	17.50	4.13	3/4x8	6.65
PT6307	0279-00204	142	20.50	18.50	19.25	16.50	28.6	33.3	1.84	17.50	4.50	3/4x8	7.31
PT7315	0279-00205	206	22.50	19.00	21.25	16.50	32.5	37.2	2.50	19.25	4.75	1x9	7.81
PT8407	0279-00206	206	22.50	19.00	21.25	16.50	31.6	36.1	2.50	19.25	4.75	1x9	8.81





POWERTORQUE® ACCESSORIES HORIZONTAL MOTOR MOUNTS

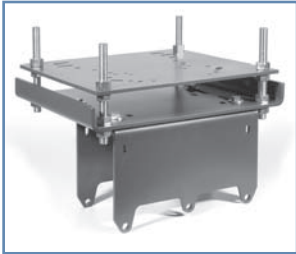

All-Steel construction for rigidity
Compact design eliminates need for motor base
Top plate adjusts for easy tensioning of drive belt
Mounting holes provided match NEMA standards

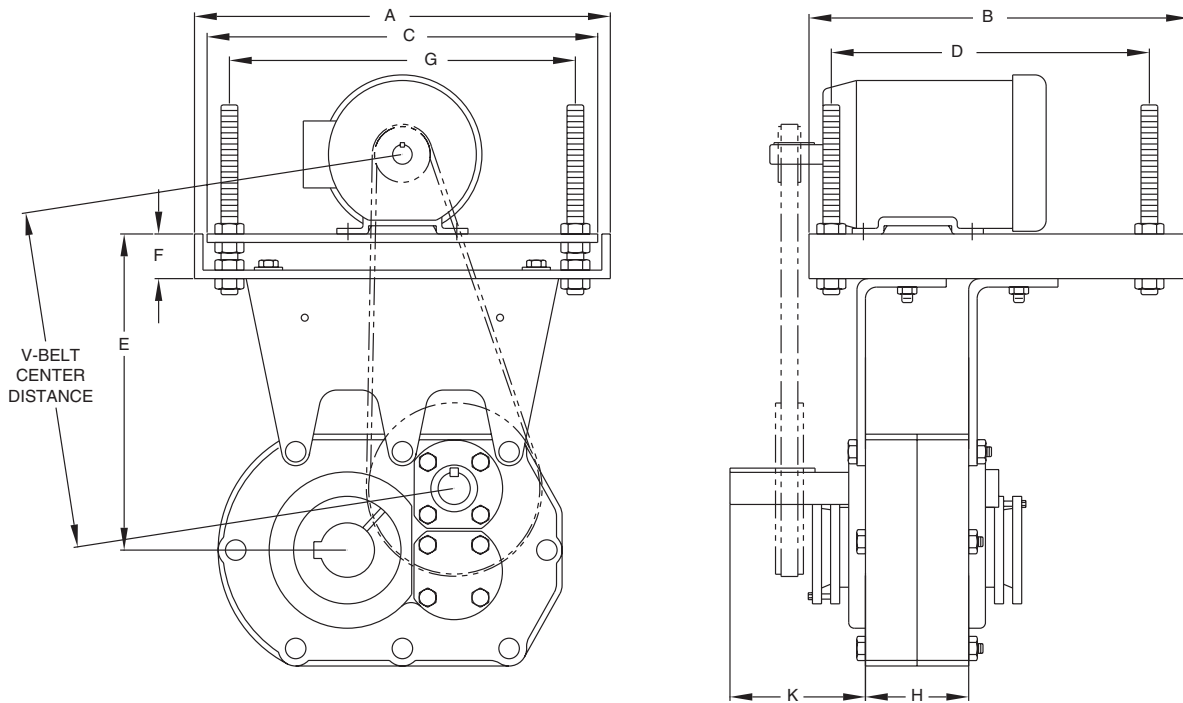

NOTE: SHIELDS/GUARDS NOT SHOWN FOR ILLUSTRATION PURPOSES



POWERTORQUE® ACCESSORIES

HORIZONTAL MOTOR MOUNTS

HORIZONTAL MOTOR MOUNTS				V-BELT CENTER DISTANCE FOR NEMA MOTOR FRAMES													
SHAFT MOUNT	PART NUMBER	NEMA MOTOR	SCREW DIAMETERS	56-140 MIN	56-140 MAX	180 MIN	180 MAX	210 MIN	210 MAX	250 MIN	250 MAX	280 MIN	280 MAX	320 MIN	320 MAX	360 MIN	360 MAX
PT1107	0279-00270	56C-215T	6 - 12	13.5	17.0	14.5	18	15.3	19.0								
PT2115	0279-00271	56C-215T	6 - 14	14.9	18.3	15.9	19.3	16.6	20.0								
PT3203	0279-00272	56C-215T	6 - 16	15.8	19.3	16.8	20.3	17.6	21.0								
PT3203	0279-00273	143T-286T	6 - 16	16.0	19.5	17.0	20.5	17.8	21.2	18.8	22.2	19.6	22.9				
PT4207	0279-00274	143T-286T	9 - 18	16.9	21.0	17.9	22.0	18.6	22.7	19.6	23.7	20.4	24.5				
PT4207	0279-00275	143T-326T	9 - 18	16.9	21.0	17.9	22.0	18.6	22.7	19.6	23.7	20.4	24.5	21.4	25.4		
PT5215	0279-00276	143T-286T	9 - 18	16.6	20.7	17.6	21.7	18.4	22.4	19.4	23.4	20.0	24.2				
PT5215	0279-00277	143T-326T	9 - 18	16.6	20.7	17.6	21.7	18.4	22.4	19.4	23.4	20.0	24.2	21.1	25.2		
PT6307	0279-00278	143T-326T	12 - 20	17.0	21.0	18.0	22.0	18.8	22.8	19.7	23.8	20.5	24.5	21.5	25.5		
PT7315	0279-00279	143T-365T	12 - 20	22.1	25.6	23.1	26.5	23.8	27.3	24.8	28.3	25.6	29.0	26.6	30.0	27.5	31.0
PT8407	0279-00280	143T-365T	NA	16.1	20.6	17.1	21.6	17.9	22.4	18.9	23.4	19.6	24.1	20.6	25.1	21.6	26.1

SHAFT MOUNT	PART NUMBER	WEIGHT (LBS.)	A	B	C	D	E		F	G	H	J	K
							MIN	MAX					
PT1107	0279-00270	39	14.63	11.00	13.50	9.25	11.1	15.3	1.59	12.00	3.38	5/8x7	3.88
PT2115	0279-00271	40	14.63	11.00	13.50	9.25	12.6	16.8	1.59	12.00	3.38	5/8x7	4.18
PT3203	0279-00272	41	14.63	11.00	13.50	9.25	13.8	18.0	1.59	12.00	4.25	5/8x8	4.88
PT3203	0279-00273	83	18.63	17.00	17.50	14.25	14.0	18.2	1.78	15.50	4.25	3/4x8	4.88
PT4207	0279-00274	97	18.63	17.00	17.50	14.25	15.3	20.1	1.78	15.50	4.63	3/4x8	6.13
PT4207	0279-00275	121	20.50	18.50	19.25	16.50	15.3	20.1	1.84	17.50	4.63	3/4x8	6.13
PT5215	0279-00276	95	18.63	17.00	17.50	14.25	15.3	20.1	1.78	15.50	4.13	3/4x8	6.65
PT5215	0279-00277	122	20.50	18.50	19.25	16.50	15.3	20.1	1.84	17.50	4.13	3/4x8	6.65
PT6307	0279-00278	123	20.50	18.50	19.25	16.50	16.7	21.4	1.84	17.50	4.50	3/4x8	7.31
PT7315	0279-00279	148	22.50	19.00	21.25	16.50	17.5	21.7	2.50	19.25	4.75	1x9	7.81
PT8407	0279-00280	148	22.50	19.00	21.25	16.50	18.3	22.8	2.50	19.25	4.75	1x9	7.81

HORIZONTAL LONG MOTOR MOUNTS

HORIZONTAL LONG MOTOR MOUNTS				V-BELT CENTER DISTANCE FOR NEMA MOTOR FRAMES													
SHAFT MOUNT	PART NUMBER	NEMA MOTOR	SCREW DIAMETERS	56-140 MIN	56-140 MAX	180 MIN	180 MAX	210 MIN	210 MAX	250 MIN	250 MAX	280 MIN	280 MAX	320 MIN	320 MAX	360 MIN	360 MAX
PT1107	0279-00290	56C-215T	14 - 20	19.5	22.9	20.5	23.9	21.2	24.7								
PT2115	0279-00291	56C-215T	16 - 20	20.9	24.3	21.9	25.3	22.6	26.0								
PT3203	0279-00292	56C-215T	18 - 20	21.8	25.3	22.8	26.3	23.6	27.0								
PT3203	0279-00293	143T-286T	18 - 20	22.0	25.5	23.0	26.5	23.8	27.2	24.8	28.2	25.6	28.9				
PT4207	0279-00294	143T-286T	20 - 24	23.2	27.0	24.2	28.0	24.9	28.6	25.9	29.6	26.7	30.4				
PT4207	0279-00295	143T-326T	20 - 24	23.2	27.0	24.2	28.0	24.9	28.6	25.9	29.6	26.7	30.4	27.4	31.4		
PT5215	0279-00296	143T-286T	20 - 24	22.9	26.6	23.9	27.6	24.7	28.4	25.7	29.4	26.4	30.1				
PT5215	0279-00297	143T-326T	20 - 24	22.9	26.6	23.9	27.6	24.7	28.4	25.7	29.4	26.4	30.1	27.1	31.2		
PT6307	0279-00298	143T-326T	24	23.2	27.0	24.2	27.9	24.9	28.7	25.9	29.7	26.7	30.5	27.6	31.4		
PT7315	0279-00299	143T-365T	24	27.3	31.1	28.3	32.1	29.1	32.9	30.1	33.9	30.8	34.7	31.8	35.6	32.7	36.6
PT8407	0279-00300	143T-365T	NA	22.0	26.5	23.0	27.5	23.8	28.3	24.8	29.3	25.5	30.0	26.5	31.0	27.5	32.0

SHAFT MOUNT	PART NUMBER	WEIGHT (LBS.)	A	B	C	D	E		F	G	H	J	K
							MIN	MAX					
PT1107	0279-00290	49	14.63	11.00	13.50	9.25	17.1	21.3	1.59	12.00	3.38	5/8x7	3.88
PT2115	0279-00291	50	14.63	11.00	13.50	9.25	18.6	22.8	1.59	12.00	3.38	5/8x7	4.18
PT3203	0279-00292	51	14.63	11.00	13.50	9.25	19.8	24.0	1.59	12.00	4.25	5/8x8	4.88
PT3203	0279-00293	93	18.63	17.00	17.50	14.25	20.0	24.2	1.78	15.50	4.25	3/4x8	4.88
PT4207	0279-00294	113	18.63	17.00	17.50	14.25	21.3	26.1	1.78	15.50	4.63	3/4x8	6.13
PT4207	0279-00295	129	20.50	18.50	19.25	16.50	21.3	26.1	1.84	17.50	4.63	3/4x8	6.13
PT5215	0279-00296	113	18.63	17.00	17.50	14.25	21.3	26.1	1.78	15.50	4.13	3/4x8	6.65
PT5215	0279-00297	140	20.50	18.50	19.25	16.50	21.3	26.1	1.84	17.50	4.13	3/4x8	6.65
PT6307	0279-00298	143	20.50	18.50	19.25	16.50	22.7	27.4	1.84	17.50	4.50	3/4x8	7.31
PT7315	0279-00299	172	22.50	19.00	21.25	16.50	23.5	27.7	2.50	19.25	4.75	1x9	7.81
PT8407	0279-00300	172	22.50	19.00	21.25	16.50	24.3	28.8	2.50	19.25	4.75	1x9	7.81





POWERTORQUE® ACCESSORIES

VERTICAL BELT GUARDS



All-Steel construction

Adjustable to fit a wide range of sheaves and motor frames

Designed for easy installation, no drilling required

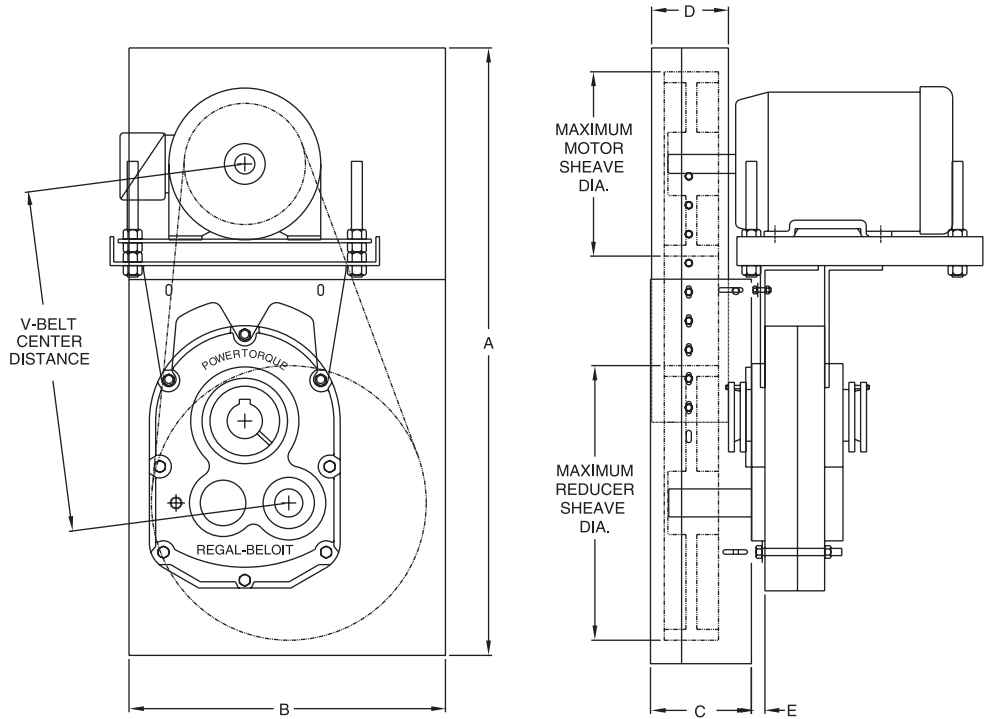

VERTICAL BELT GUARDS													
SHAFT MOUNT MODEL	BELT GUARD PART NUMBER	NEMA MOTOR FRAME	WEIGHT (LBS.)	V-BELT CENTER DISTANCE		MAXIMUM SHEAVE DIA.		A		B	C	D	E
				MIN	MAX	MOTOR	REDUCER	MIN.	MAX.				
PT1107	0279-00371	56C-215T	51	17.6	22.7	6.4	18.0	31.75	39.75	22.00	5.40	4.31	0.56
PT2115	0279-00375	56C-215T	54	18.7	23.9	8.6	19.0	32.75	40.75	22.00	5.40	4.31	0.56
PT3203	0279-00379	56C-286T	57	20.2	27.2	8.6	19.0	35.75	43.75	22.00	5.40	4.31	0.56
PT4207	0279-00383	143T-326T	71	21.2	29.8	12.0	19.0	40.25	48.25	23.50	6.90	5.31	0.63
PT5215	0279-00387	143T-326T	75	22.7	31.2	12.0	19.0	41.75	49.75	23.50	6.90	5.31	0.63
PT6307	0279-00391	143T-326T	104	25.9	34.2	14.0	25.0	48.25	56.25	29.25	8.70	7.44	2.00
PT7315	0279-00395	143T-365T	126	30.6	39.9	14.0	30.0	55.25	63.25	34.25	8.70	7.44	1.25
PT8407	0279-00399	143T-365T	126	31.9	41.2	14.0	30.0	55.25	63.25	34.25	8.70	7.44	1.25

VERTICAL LONG BELT GUARDS													
SHAFT MOUNT MODEL	BELT GUARD PART NUMBER	NEMA MOTOR FRAME	WEIGHT (LBS.)	V-BELT CENTER DISTANCE		MAXIMUM SHEAVE DIA.		A		B	C	D	E
				MIN	MAX	MOTOR	REDUCER	MIN.	MAX.				
PT1107	0279-00372	56C-215T	55	20.6	25.7	6.4	18.0	34.50	42.50	22.00	5.40	4.31	0.56
PT2115	0279-00376	56C-215T	57	21.7	26.9	8.6	19.0	35.50	43.50	22.00	5.40	4.31	0.56
PT3203	0279-00380	56C-286T	60	23.2	30.2	8.6	19.0	38.75	46.75	22.00	5.40	4.31	0.56
PT4207	0279-00384	143T-326T	82	25.7	34.3	12.0	19.0	44.50	52.50	23.50	6.90	5.31	0.63
PT5215	0279-00388	143T-326T	80	29.5	37.9	12.0	19.0	48.00	56.00	23.50	6.90	5.31	0.63
PT6307	0279-00392	143T-326T	123	39.9	48.2	14.0	25.0	62.25	70.25	29.25	8.70	7.44	2.00
PT7315	0279-00396	143T-365T	150	45.6	54.9	14.0	30.0	71.00	79.00	34.25	8.70	7.44	1.25
PT8407	0279-00400	143T-364T	150	44.9	54.3	14.0	30.0	71.00	79.00	34.25	8.70	7.44	1.25



POWERTORQUE® ACCESSORIES

HORIZONTAL BELT GUARDS



All-Steel construction

Adjustable to fit a wide range of sheaves and motor frames

Designed for easy installation, no drilling required

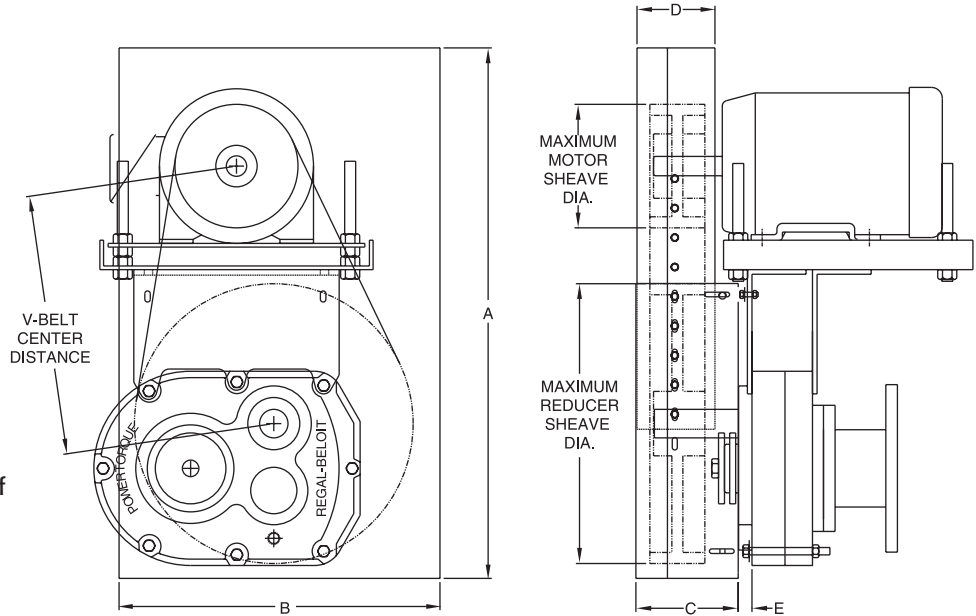

HORIZONTAL BELT GUARDS													
SHAFT MOUNT MODEL	BELT GUARD PART NUMBER	NEMA MOTOR FRAME	WEIGHT (LBS.)	V-BELT CENTER DISTANCE		MAXIMUM SHEAVE DIA.		A		B	C	D	E
				MIN	MAX	MOTOR	REDUCER	MIN.	MAX.				
PT1107	0279-00373	56C-215T	48	13.5	19.0	6.4	18.0	27.75	35.75	22.00	5.40	4.31	0.56
PT2115	0279-00377	56C-215T	51	14.9	20.0	8.6	19.0	28.75	36.75	22.00	5.40	4.31	0.56
PT3203	0279-00381	56C-286T	53	15.8	22.9	8.6	19.0	31.50	39.50	22.00	5.40	4.31	0.56
PT4207	0279-00385	143T-326T	67	16.9	25.4	12.0	19.0	36.25	44.25	23.50	6.90	5.31	0.63
PT5215	0279-00389	143T-326T	64	16.6	25.2	12.0	19.0	35.75	43.75	23.50	6.90	5.31	0.63
PT6307	0279-00393	143T-326T	92	17.0	25.5	14.0	25.0	39.50	47.50	29.25	8.70	7.44	2.00
PT7315	0279-00397	143T-365T	105	22.1	31.0	14.0	30.0	41.75	49.75	34.25	8.70	7.44	1.25
PT8407	0279-00401	143T-365T	105	16.1	25.4	14.0	30.0	41.75	49.75	34.25	8.70	7.44	1.25

HORIZONTAL LONG BELT GUARDS													
SHAFT MOUNT MODEL	BELT GUARD PART NUMBER	NEMA MOTOR FRAME	WEIGHT (LBS.)	V-BELT CENTER DISTANCE		MAXIMUM SHEAVE DIA.		A		B	C	D	E
				MIN	MAX	MOTOR	REDUCER	MIN.	MAX.				
PT1107	0279-00374	56C-215T	53	19.5	24.7	6.4	18.0	33.75	41.75	22.00	5.40	4.31	0.56
PT2115	0279-00378	56C-215T	56	20.9	26.0	8.6	19.0	34.75	42.75	22.00	5.40	4.31	0.56
PT3203	0279-00382	56C-286T	59	21.8	28.9	8.6	19.0	37.25	45.25	22.00	5.40	4.31	0.56
PT4207	0279-00386	143T-326T	73	23.2	31.4	12.0	19.0	41.50	49.50	23.50	6.90	5.31	0.63
PT5215	0279-00390	143T-326T	73	22.9	31.2	12.0	19.0	42.00	50.00	23.50	6.90	5.31	0.63
PT6307	0279-00394	143T-326T	100	23.2	31.4	14.0	25.0	45.50	53.50	29.25	8.70	7.44	2.00
PT7315	0279-00398	143T-365T	115	27.3	36.6	14.0	30.0	48.00	56.00	34.25	8.70	7.44	1.25
PT8407	0279-00402	143T-365T	115	22.0	31.4	14.0	30.0	48.00	56.00	34.25	8.70	7.44	1.25

COOLING FANS

Available upon request, consult factory for details



POWERTORQUE® ACCESSORIES

SCREW CONVEYOR DRIVE

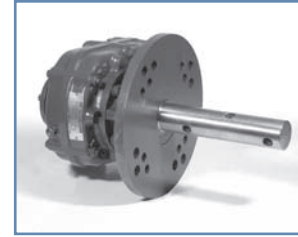
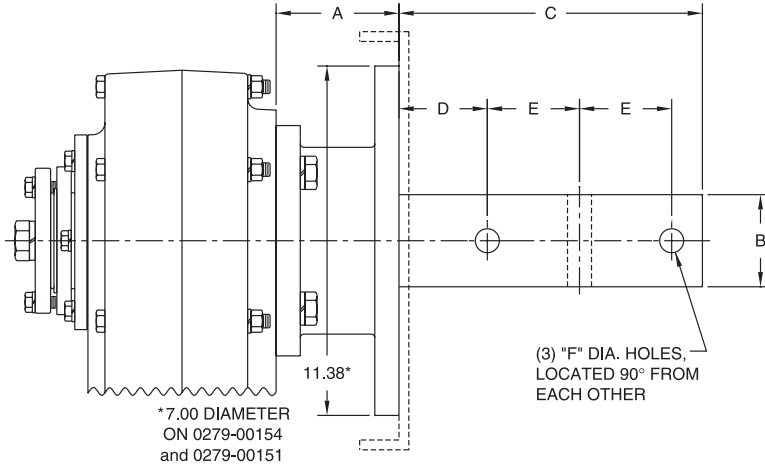

Shaft Mount Model	Adaptor Flanges			Drive Shafts							
	Part Number	Weight (lbs.)	A	Part Number	Weight (lbs.)	B	C	D	E	F	Screw Size
PT1107	0279-00151	13	3.22	0279-00211	14	1.500	9.00	2.12	3.00	17/32	6
				0279-00212	17	2.000	9.00	2.12	3.00	21/32	9, 12
	0279-00152	27	3.22	0279-00213	22	2.437	9.69	2.75	3.00	21/32	12, 14
				0279-00214	29	3.000	9.88	2.88	3.00	25/32	12 - 20
				0279-00215	15	1.500	9.00	2.12	3.00	17/32	6
PT2115	0279-00154	15	3.56	0279-00216	18	2.000	9.00	2.12	3.00	21/32	9, 12
				0279-00217	23	2.4375	9.69	2.75	3.00	21/32	12, 14
	0279-00153	25	3.56	0279-00218	30	3.000	9.88	2.88	3.00	25/32	12 - 20
				0279-00219	20	1.500	9.00	2.12	3.00	17/32	9
				0279-00220	23	2.000	9.00	2.12	3.00	21/32	9, 12
PT3203	0279-00155	29	3.69	0279-00221	28	2.4375	9.69	2.75	3.00	21/32	12, 14
				0279-00222	35	3.000	9.88	2.88	3.00	25/32	12 - 20
				0279-00223	24	1.500	9.00	2.12	3.00	17/32	9
				0279-00224	27	2.000	9.00	2.12	3.00	21/32	9, 12
				0279-00225	32	2.4375	9.69	2.75	3.00	21/32	12, 14
PT4207	0279-00156	33	4.00	0279-00226	39	3.000	9.88	2.88	3.00	25/32	12 - 20
				0279-00227	53	3.4375	13.13	3.88	4.00	29/32	18 - 24
				0279-00228	37	2.000	9.00	2.12	3.00	21/32	9, 12
				0279-00229	42	2.4375	9.69	2.75	3.00	21/32	12, 14
				0279-00230	49	3.000	9.88	2.88	3.00	25/32	12 - 20
PT5215	0279-00157	43	4.25	0279-00231	63	3.4375	13.13	3.88	4.00	29/32	18 - 24
				0279-00232	57	2.4375	9.69	2.75	3.00	21/32	12, 14
				0279-00233	64	3.000	9.88	2.88	3.00	25/32	12 - 20
				0279-00234	78	3.4375	13.13	3.88	4.00	29/32	18 - 24
				0279-00235	73	2.4375	9.69	2.75	3.00	21/32	12, 14
PT6307	0279-00158	56	5.50	0279-00236	80	3.000	9.88	2.88	3.00	25/32	12 - 20
				0279-00237	94	3.4375	13.13	3.88	4.00	29/32	18 - 24
				0279-00238	64	3.000	9.88	2.88	3.00	25/32	12 - 20
				0279-00239	78	3.4375	13.13	3.88	4.00	29/32	18 - 24
PT7315	0279-00159	72	6.50	0279-00240	80	3.000	9.88	2.88	3.00	25/32	12 - 20
				0279-00241	94	3.4375	13.13	3.88	4.00	29/32	18 - 24
				0279-00242	80	3.000	9.88	2.88	3.00	25/32	12 - 20

ADAPTER FLANGES

Conform to CEMA standards. Bolt-on design allows easy mounting. Open center for contaminate dropout.



DRIVE SHAFTS

Conform to CEMA dimensional standards. Machined from high strength alloy steel. Easy installation into standard hollow bore.



AUXILIARY SEAL KITS

Available upon request, consult factory for details